

LEYBOLD®

THE MULTIMEDIA LAB FOR ELECTRONICS AND ELECTRICAL ENGINEERING

COM3LAB

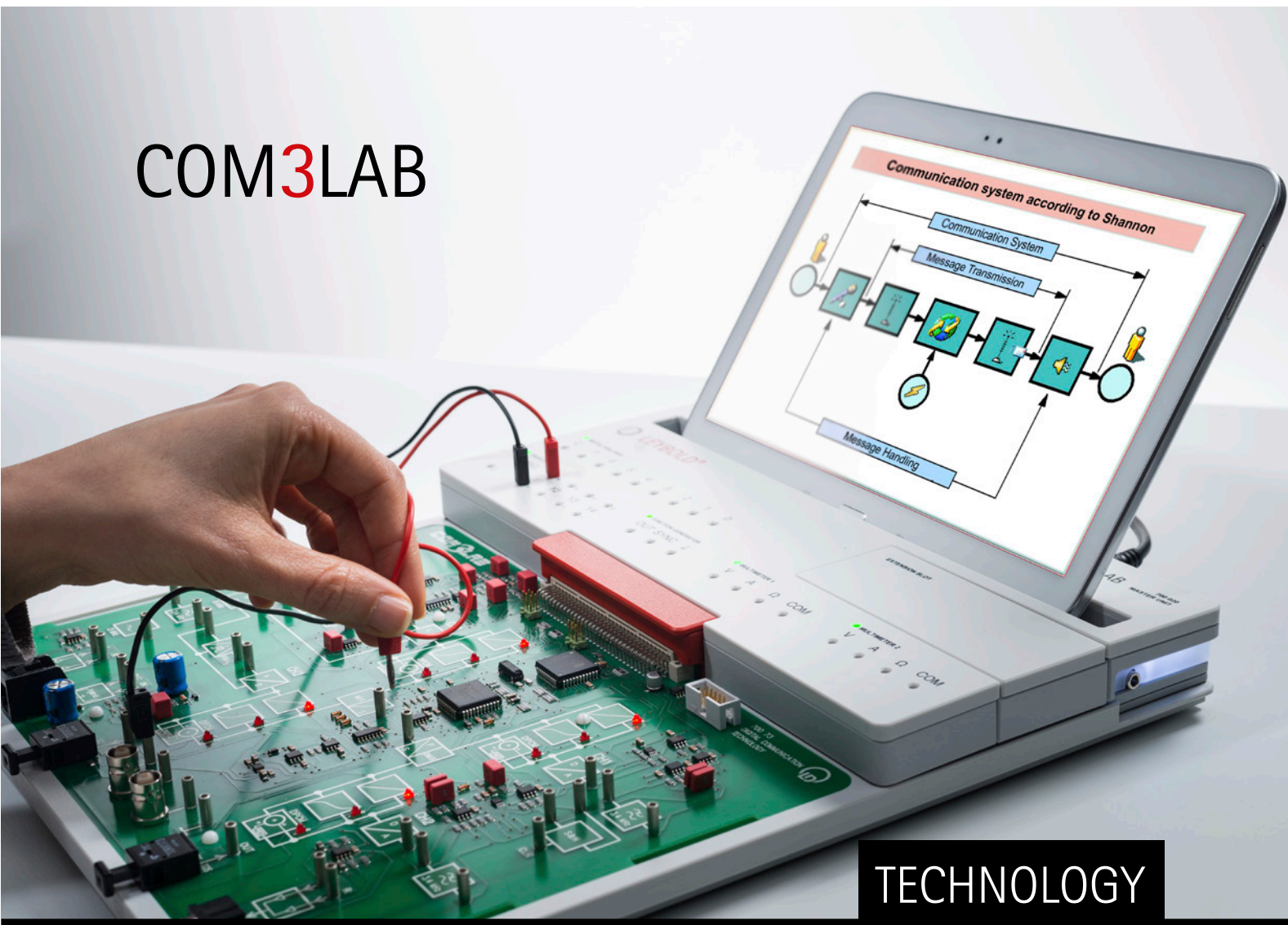

TECHNOLOGY

LEARNING WITH A GUARANTEE OF SUCCESS

- safe experiments
- comprehensive content
- easy handling



COM3LAB

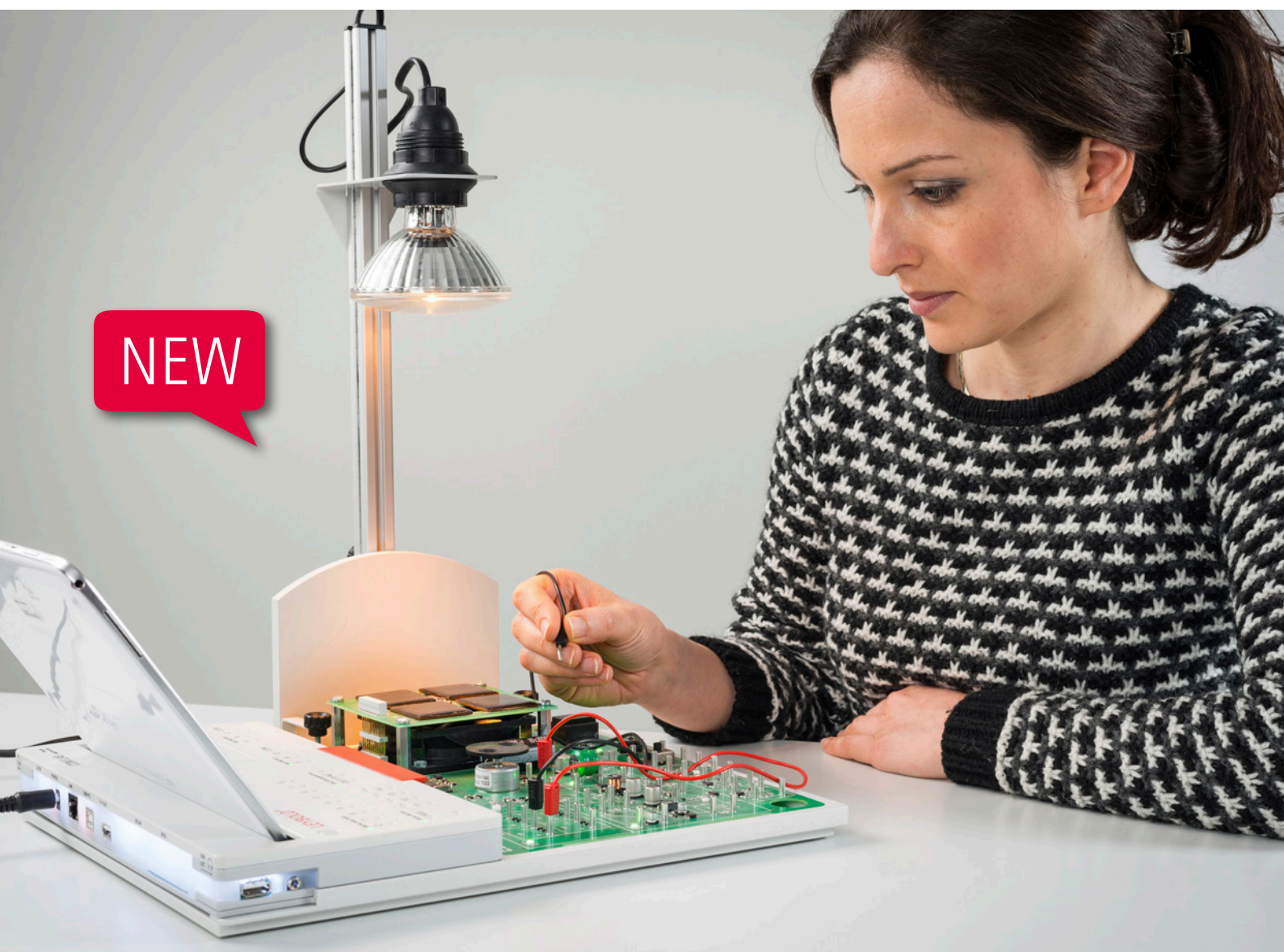

THE MULTIMEDIA LAB
FOR ELECTRONICS AND
ELECTRICAL ENGINEERING

CONTENT

COM3LAB – THE SYSTEM AT A GLANCE

3 components	4-5
The new Master Unit, also available for tablets	6-9
The concept	10-11
Safety – two steps ahead	12-13
Compatible with any laboratory equipment	14-15
Courses for every level of education	16-17

ELECTRICAL ENGINEERING

FUNDAMENTALS	
DC Technology	20
AC Technology	21
Electronic components	22
Digital Technology	23
Operational Amplifiers	24
Three-Phase Technology	25
Measurement Technology	26

SPECIALIZATIONS

Mechatronics	27
Measuring, control and regulation	28
Drive Technology	29
Motors & Generators	30
Communications Technology	31
Communications Networks	32
Radiolocation	33
RF Technology	34
Microcontroller Technology	35

PROJECTS

Circuit Design	36
Digital control lines	37
Analogue control lines	38
Automation Technology	39
Power Electronics	40
Drive Technology	41

COM3LAB

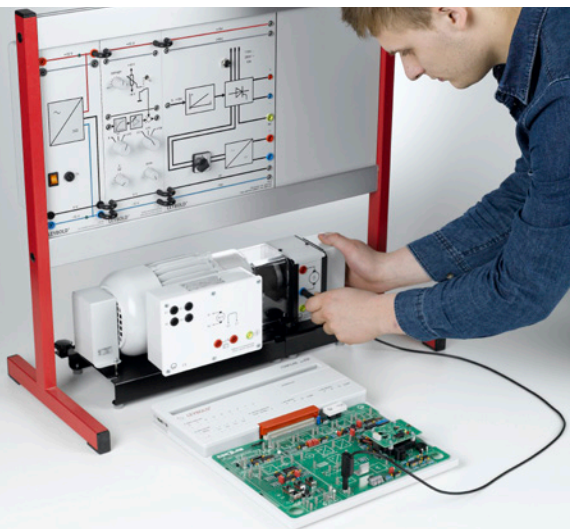

AUTOMOTIVE TECHNOLOGY

FUNDAMENTALS

Electrics	44
Sensors	45
Digital Technology	46

SPECIALIZATIONS

Bus Systems	47
-------------	----

RENEWABLE ENERGY

FUNDAMENTALS

Photovoltaics	50
---------------	----

PRODUCT SECTION

Individual components

from 51

3 COMPONENTS

turn to one **LABORATORY**

The COM3LAB learning environment combines experimentation with the advantages of interactive e-learning.

The new Master Unit is the bridge between the experimental panel and the learning software. It contains all necessary measuring instruments and power supplies.

MASTER UNIT

- clearly labelled with a functional design
- interfaces to all PC systems
- precise and rapid measuring instruments and signal generators
- robust against electromagnetic interference
- simple and safe in the hands of students
- compatible with all previous COM3LAB courses

NEW

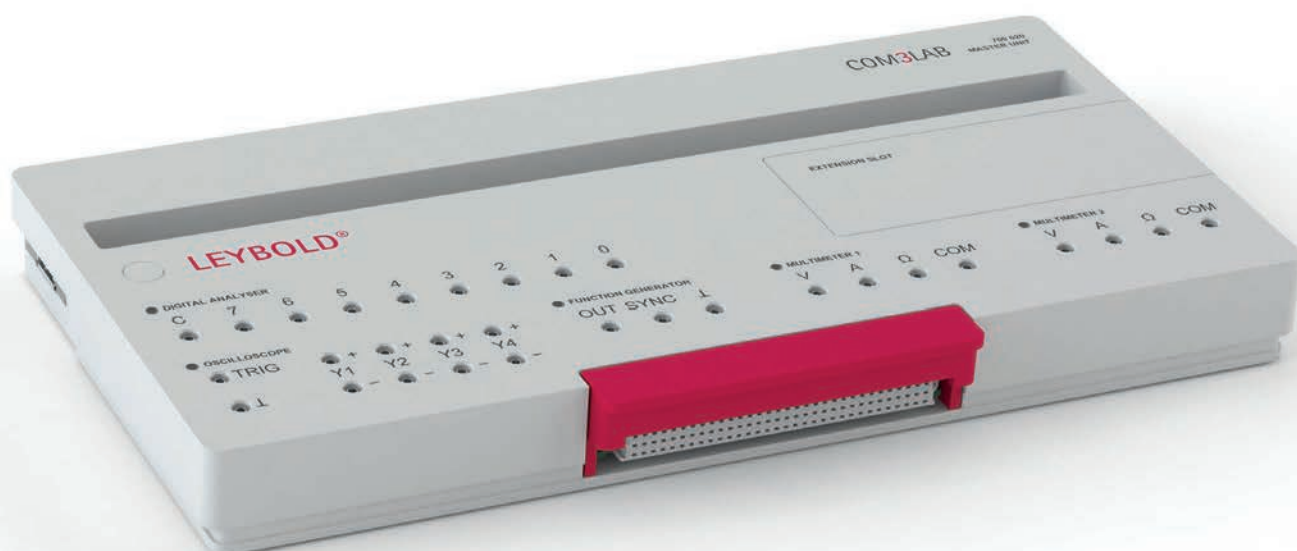

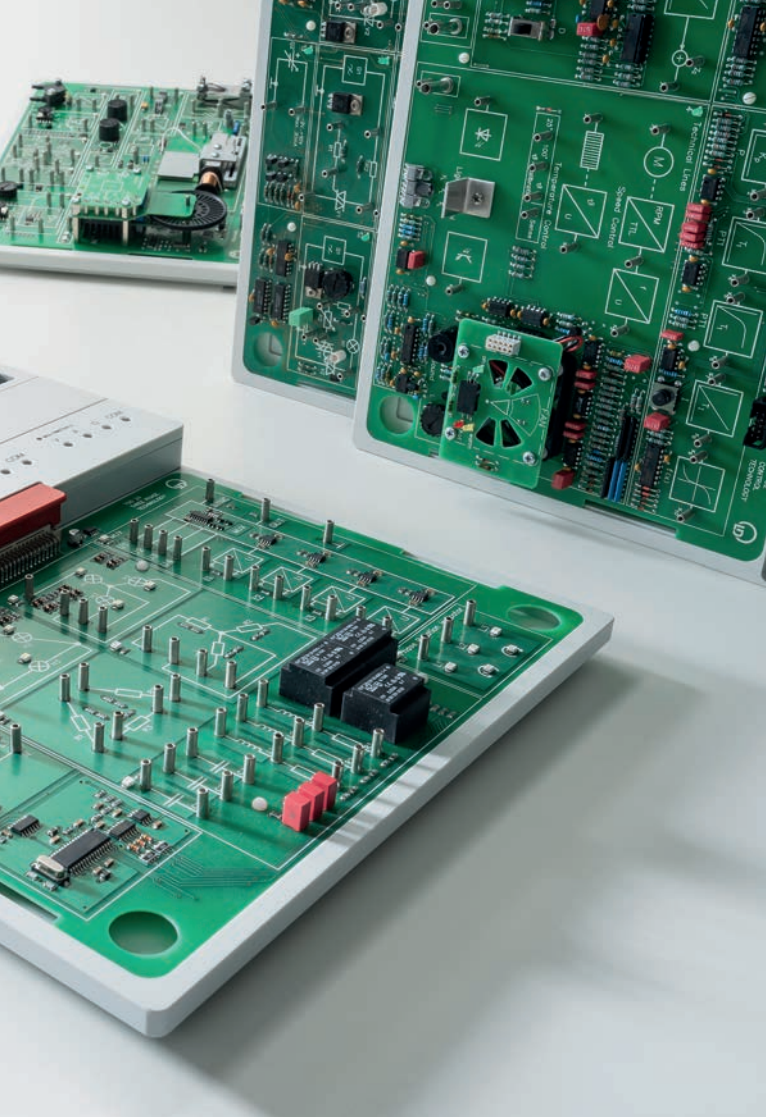

COM3LAB

EXPERIMENT BOARD

- safe and clearly structured courses for every learning field of electrical engineering
- regular new courses on modern topics
- visible modules and realistic system components
- interactive course guidance with LEDs



INTERACTIVE LEARNING SOFTWARE

- clearly structured, simple operation
- easily understandable theoretical part
- all experiments performed under guidance with learning control tests
- multimedia support content with animations, videos, audio and real measuring instruments with virtual display

THE NEW MASTER UNIT

EVEN BETTER FOR TEACHERS AND TRAINERS



FOR TABLET,
PC AND LAPTOP

No matter if and how your IT system changes tomorrow, the new Master Unit fits into any modern infrastructure. Whether USB, WiFi or Ethernet, all interfaces are supported directly, and without adapters.

Windows systems are supported natively, iOS and Android systems can be easily connected via RDP or VNC.

PROTECTION FROM DESTRUCTION

Safety features for a long service life in the teaching laboratory:

- The red security lock keeps the course board mechanically secure and if it is opened, the course board is switched off.
- To meet current regulations, 2 mm security cable can also be used.
- There is a slot for a Kensington lock on the rear side, so that your Master Unit remains in the place where you need it.
- Course board frames made from high-quality material protect the PCB and the furniture against scratches and defects.
- The use of high-quality materials.



ASSEMBLY AND DISASSEMBLY
QUICK AND EASY

- The compact construction permits space-saving storage in a cupboard.
- Course boards can be connected to the new Master Unit quickly.

COM3LAB

HIGHER MOTIVATION AND GREATER LEARNING SUCCESS FOR STUDENTS

INTUITIVE LEARNING, FUNCTIONAL DESIGN

The Master Unit has been designed to allow perfect learning ergonometry:

- Complete and easily readable labelling.
- Multi-coloured activity indicators for measuring instruments.
- A luminous strip indicates to the instructor(s) whether a course is being actively carried out.
- All measuring instruments can be controlled directly by the software.



NEW 4-CHANNEL OSCILLOSCOPE

The integrated oscilloscope offers many advantages:

- Four differential inputs
- Measuring rate: 2 M-samples per channel
- Resolution: 12 bits per channel
- Memory depth: 4 K-samples per channel

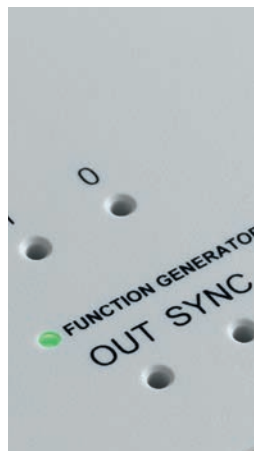
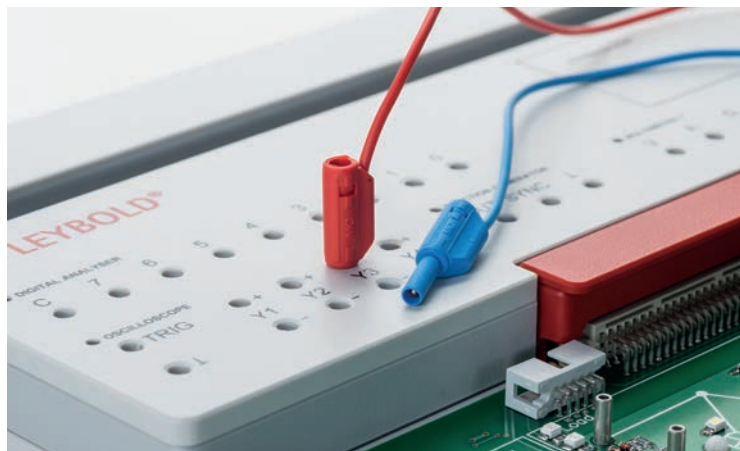

ACTIVE GUIDANCE

The relevant areas light up during the course of the experiment to guide the user through the experiment.

COMPATIBLE WITH ALL COURSE BOARDS

The course board frame acts as an "adapter" for all basic and advanced course boards. The frames can be purchased individually.

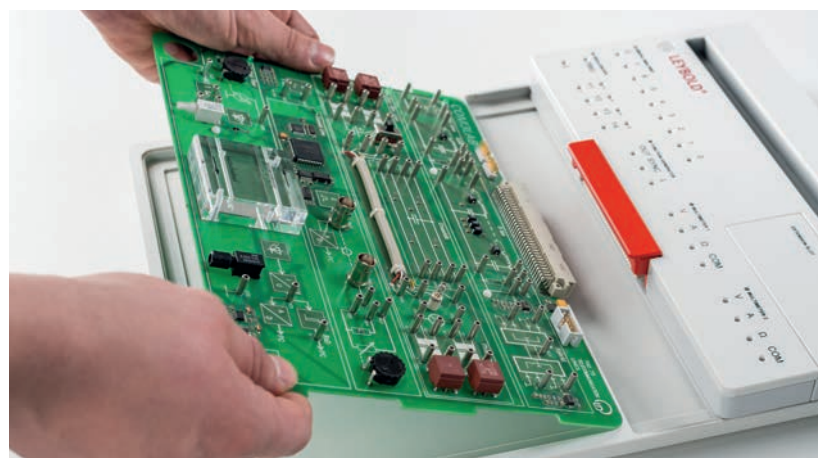

THE NEW MASTER UNIT

COMPLETELY REVISED
FUNCTIONAL DESIGN

FOR TABLETS
Interfaces for many
available models



ANTI-THEFT PORT
using a Kensington lock

PC interface for controlling
course boards (RJ45/USB/WLAN)

FUNCTION GENERATOR

up to 100 KHz
Square-wave, triangular,
sinusoidal, DC

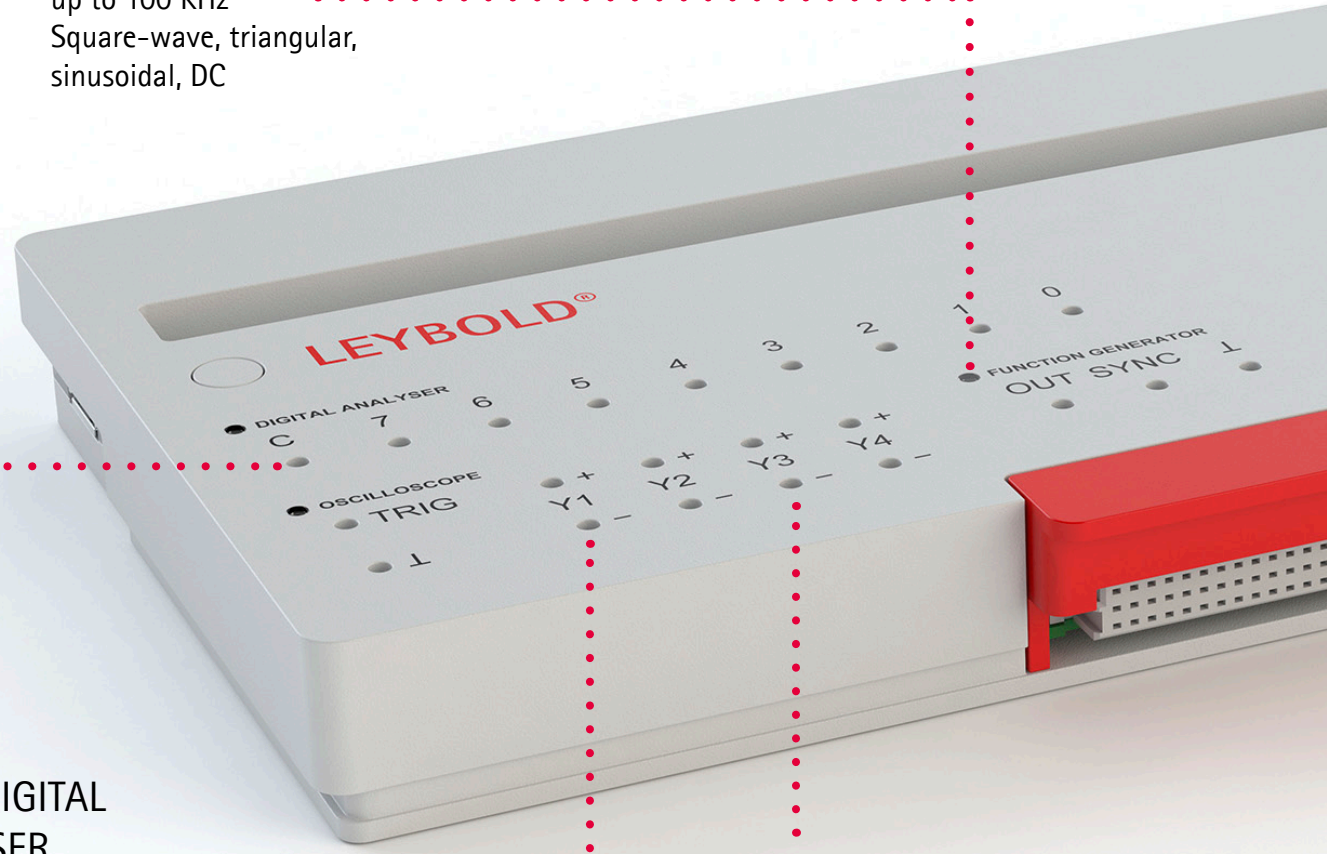

8-BIT DIGITAL
ANALYSER

2 mm safety sockets

4-CHANNEL
OSCILLOSCOPE
with differential inputs

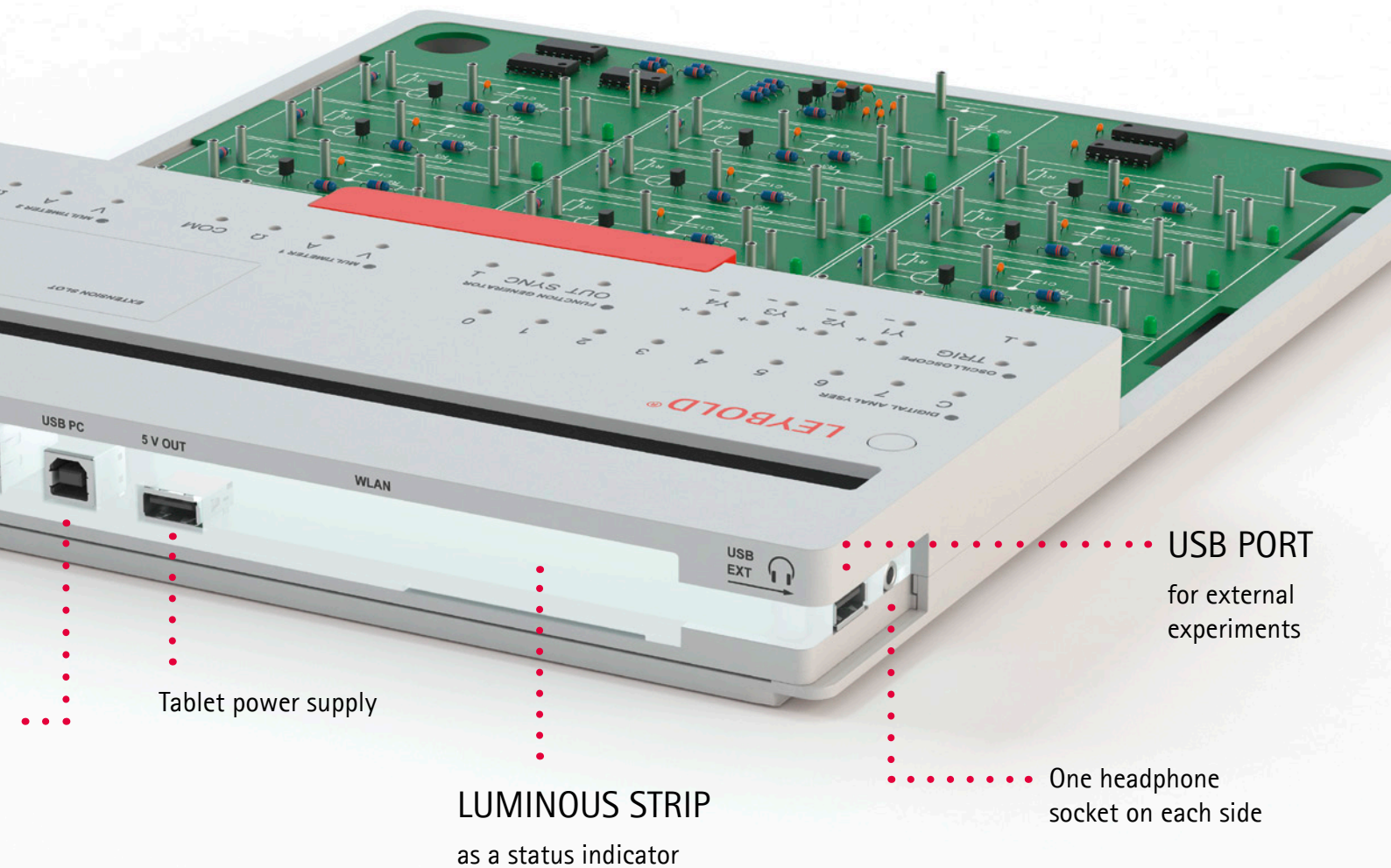

Tablet power supply

LUMINOUS STRIP
as a status indicator

USB PORT
for external
experiments

One headphone
socket on each side

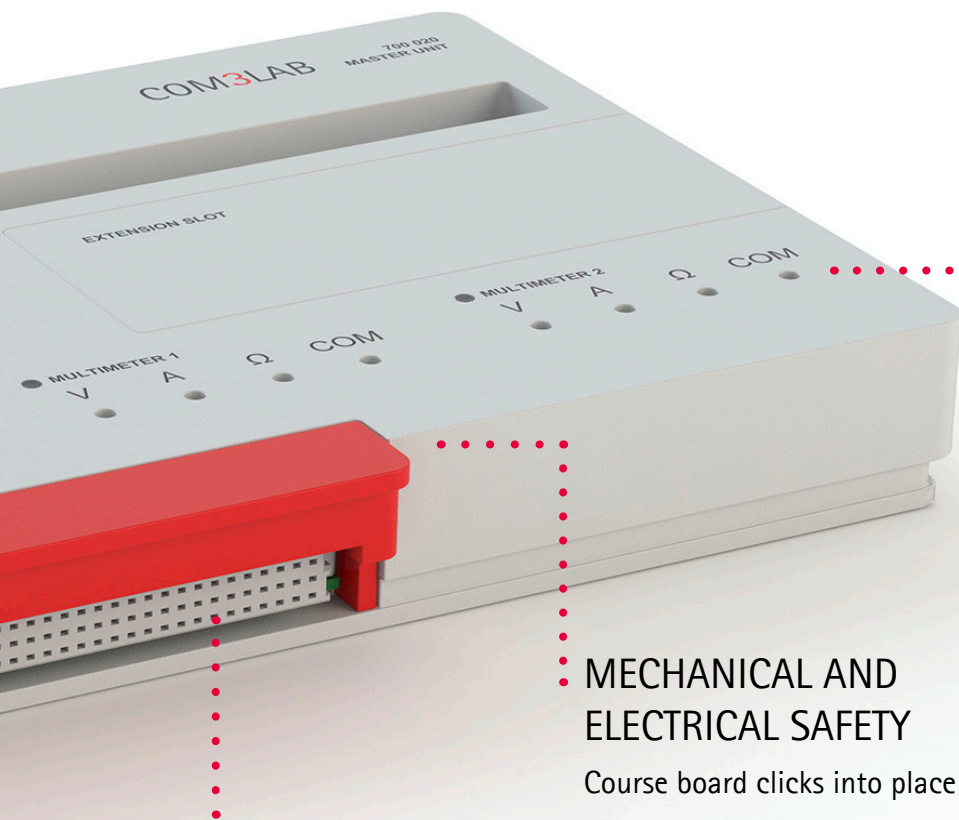

2 x MULTIMETER
8 measurement ranges
for current, voltage and
resistance measurement

MECHANICAL AND
ELECTRICAL SAFETY
Course board clicks into place

RASTER SLOT FOR
EXPERIMENT BOARDS
compatible with COM3LAB 1.0

COM3LAB

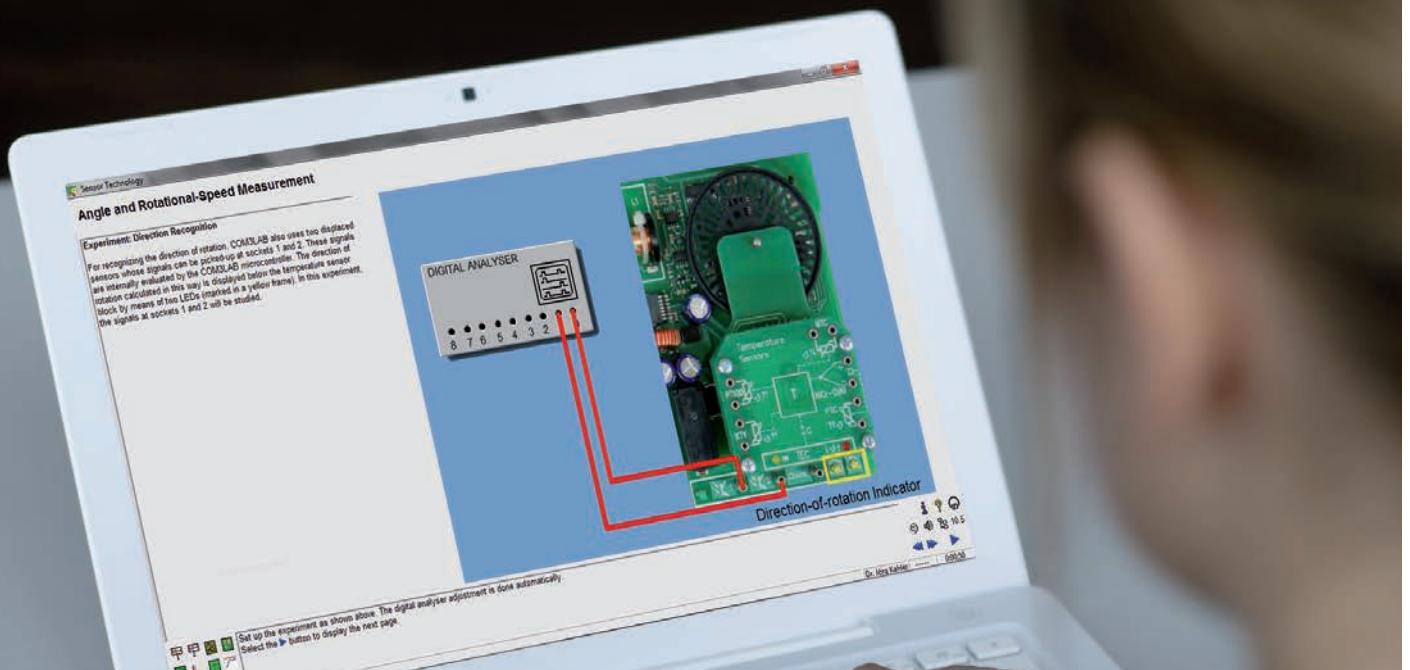

INTERACTIVE LEARNING PROGRAMME TEACHES AND GUIDES THROUGH THE CONTENTS

Often copied - never equalled. Owing to the clear and consistent preparation of the teaching content, the learning software clearly and unmistakably provides guidance through the individual experiments. Every topic starts with a theoretical introduction followed by at least one topic-related, practical experiment. The COM3LAB self-assessment test ensures that the course content is absorbed and consolidated.

The interactive COM3LAB learning software is suitable for independent learning and experimenting as well as for complete teaching units and project work. The multimedia learning environment supports the real experiments additionally with graphics, animations, videos and optionally with audio.

All courses are available not only in German and in English, but also the courses already support many other languages, such as Spanish, Russian, Polish, etc.



PRACTICE-ORIENTATED EXPERIMENTS
INCREASE LEARNING OUTCOMES

ADVANTAGES

FOR THE TEACHER

- comprehensive content
- practice-oriented experiments
- descriptive teaching materials for presentations
- documentation with solutions
- flexible application for teaching
- time-saving through quick and simple assembly

FOR THE STUDENT

- practice-oriented learning
- review of the results
- documentation of the results
- team work or independent study
- language selection
- adapted to the individual's learning speed
- promotes decision-making and responsibility

SAFETY

TWO STEPS AHEAD

A comprehensive safety concept has been developed for the new COM3LAB.

PROTECTION FROM DESTRUCTION

Apart from the careful choice of materials and a robust design, this aspect includes the protection of the course provided by the new course frameworks.

PROTECTION AGAINST DANGEROUS VOLTAGES

In all COM3LAB courses, only safe voltages and low currents are used. This rules out any hazard. In order to comply additionally with the new regulations in many teaching establishments, the courses can be operated with safety cables.

PROTECTION FROM THEFT

There is a compatible slot for a Kensington lock on the rear side of the Master Unit. In addition, every networkable Master Unit is equipped with a unique ID for easy assessment management.

SO THAT YOU CAN CONCENTRATE ON
WHAT'S IMPORTANT



SHORT PREPARATION TIME

ASSEMBLY AND DISASSEMBLY IN ONLY A FEW MINUTES



COURSE DEVICES ARE MECHANICALLY LOCKED AND AUTOMATICALLY ACTIVATED

1. OPEN THE SECURITY LOCK AND PUSH THE MASTER UNIT INTO PLACE
2. CLOSE THE SECURITY LOCK
3. SWITCH ON THE MASTER UNIT
4. START THE SOFTWARE
START TRAINING

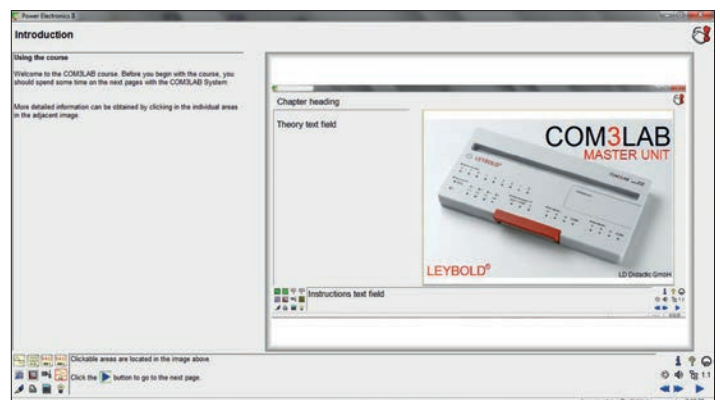

Introduction to the COM3LAB course

COMPATIBLE WITH ANY LABORATORY EQUIPMENT ...



FOR TABLETS

The slot in the Master Unit is designed to accept many available 8-10" tablets.

Simply establish a connection via WiFi, Ethernet or USB.

An additional charging port at the rear of the Master Unit ensures long-term learning pleasure.

LAPTOP AND PC

For use with laptops and PCs, we recommend Windows 7 or Windows 8.

Now all possibilities are open to you. For better documentation, the course pages can be saved and printed, i.e. as PDF, XPS,

The results of measurements can be further processed in Word and Excel.

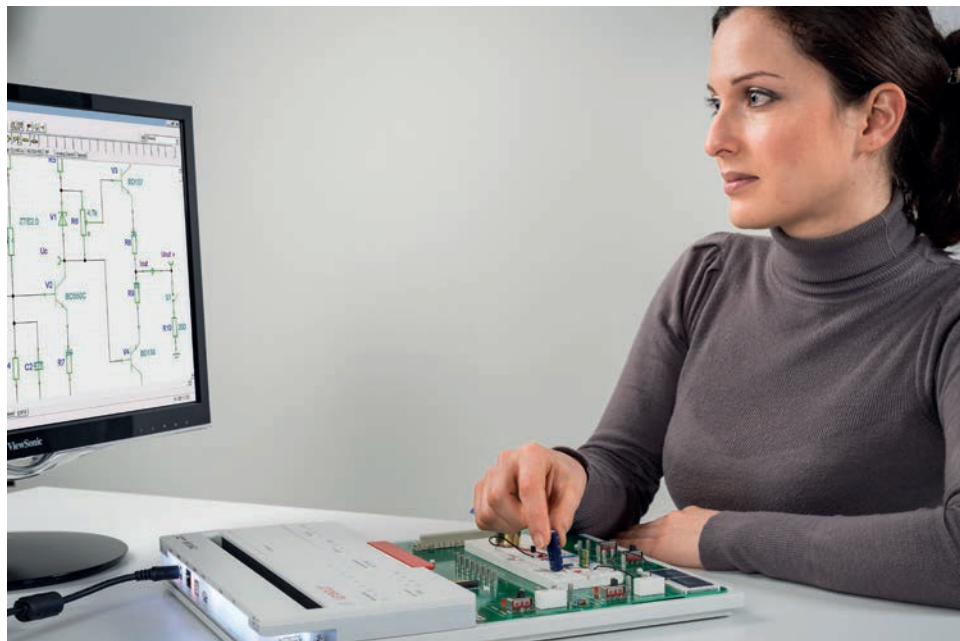

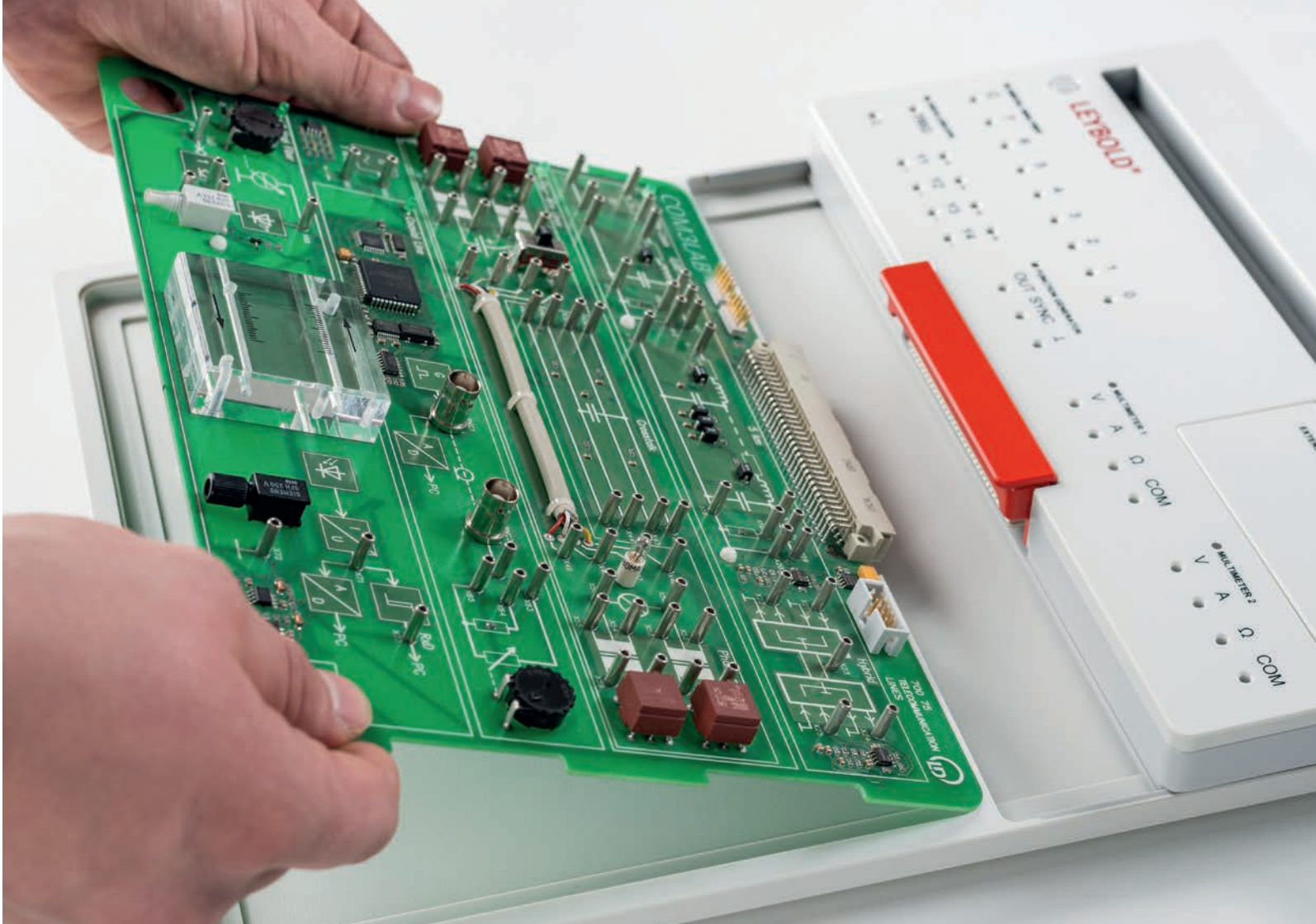

COMPATIBLE WITH OLDER
COURSE BOARDS

... AND ALL COURSE BOARD GENERATIONS

What once was good, will be further used. For this reason, the new Master Unit and also the learning software support older course boards.

All that you need is the new course board frame (700 022) which can be bought economically in sets. Click your existing experiment boards into the frames and your equipment is fit for the new learning generation with COM3LAB. The new software supports both the Master Unit 700 00USB and also the new Master Unit 700 020, so that parallel operation is possible.

COM3LAB

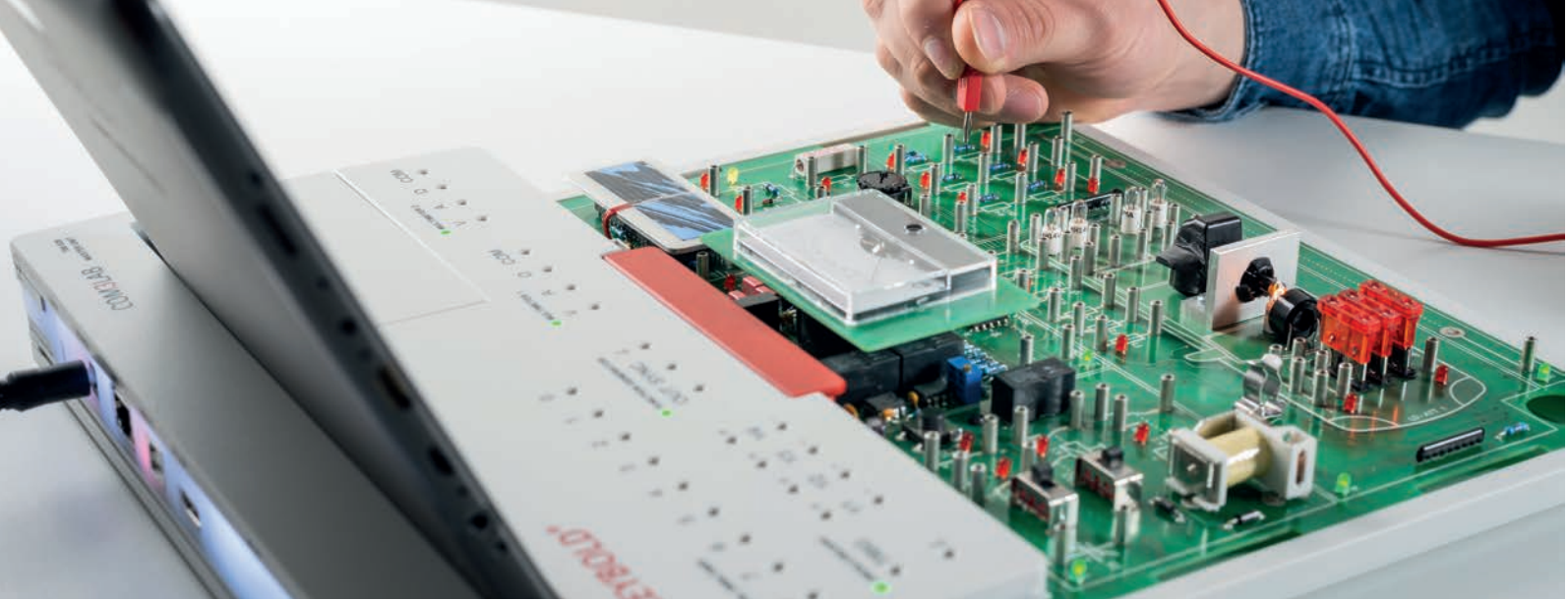

COURSES FOR EVERY LEVEL OF EDUCATION

Detailed descriptions of the courses are available in the product section from page 51.

ELECTRONICS TECHNICIAN FOR AUTOMOTIVE TECHNOLOGY

		7006401	7006501	7006101	7006201	7006301	7003501
Topics:	Testing and maintenance of electrical and electronic systems	x	x	x			
	Testing and maintenance of the power supply and starting systems				x		
	Testing and maintenance of networked systems					x	
	Testing and maintenance of electro-pneumatic and hydraulic systems						x

ELECTRONICS TECHNICIAN FOR AUTOMATION

		7001101	7001201	7001301	7001401	7001701	7001801	7002401	7003101	7003501	7007501	7008201
Topics:	Analyse electrical systems and check functions	x	x	x	x							
	Analyse and adjust controls					x	x					
	Ensure electricity supply and safety of equipment							x				
	Analyse and verify systems and equipment									x		
	Program and implement controls for systems								x			x
	Integrate control and communication systems										x	
	Plan automation systems								x			
	Implement automation systems								x			

ELECTRONICS TECHNICIAN FOR ENERGY AND BUILDING

		7001101	7001201	7001301	7001401	7001701	7001801	7002401	7005301	7003101	7008201
Topics:	Analyse electrical systems and check functions	x	x	x	x				x		
	Analyse and adjust controls					x	x				
	Ensure electricity supply and safety of equipment							x			
	Program and implement controls for systems									x	x

ELECTRONICS TECHNICIAN FOR DEVICES AND SYSTEMS

		7001101	7001201	7001301	7001401	7001701	7001801	7005301	7003101	7003601	70039	7008201	7008301	7003501
Topics:	Analyse electrical systems and check functions	x	x	x	x			x						
	Analyse and adjust controls					x	x							
	Configure assemblies of hardware and software								x	x	x	x	x	
	Produce equipment and check													x

ELECTRONICS TECHNICIAN FOR INFORMATION / TELECOMMUNICATIONS TECHNOLOGY

		7001101	7001201	7001301	7001401	7001701	7001801	7002401	7005301	7001901	7003101	70039	7003501	7008201
Topics:	Analyse electrical systems and check functions	x	x	x	x									
	Analyse and adjust controls					x	x							
	Ensure electricity supply and safety of equipment							x						
	Program and implement controls for systems									x				x
	Select and integrate systems									x	x	x	x	

COM3LAB

TECHNICAL COLLEGE / UNIVERSITY

.....
 suitable for practical work in fundamental principles, tutorials and for independent study

TECHNICAL- / MASTER SCHOOL

.....
 suitable for project work and independent study

VOCATIONAL SCHOOLS

.....
 suitable for demonstration and practical teaching

LEARNING LEVEL

ADVANCED TOPICS

BASICS

ELECTRONICS TECHNICIAN AERONAUTICAL SYSTEMS

		7001101	7001201	7001301	7001401	7001701	7001801	7003101	7003601	70039	7007101	7007201	7007401	7007501	7376001	7008201	7008301
Topics:	Analyse electrical systems and check functions	x	x	x	x												
	Analyse and adjust controls					x	x										
	Take systems and devices in aircraft in operation					x	x	x	x	x				x			
	Install and maintain information and communication systems of aircraft										x	x	x		x		
	Check and adjust automated systems in aircraft															x	x

INFORMATION ELECTRONICS TECHNICIAN

		7001101	7001201	7001301	7001401	7001501	7001601	7001701	7001801	7003601	70039	7007101	7007301	7007401	7008101	735801
Topics:	Install equipment, plant and systems of information technology	x	x	x	x											
	Capture and represent signal processing operations in information technology equipment							x	x			x	x	x	x	
	Analyse the function of selected assemblies and components of information technology equipment					x	x	x	x							
	Configure and optimize a single-user computer in line with order									x	x					
	Analyse errors on devices and systems for video, audio and data technology												x	x		
	Set up and use services and multimedia components as needed													x		x

ELECTRONICS TECHNICIAN FOR MACHINE AND DRIVE TECHNOLOGY

		7001101	7001201	7001301	7001401	7001701	7001801	7002401	7002501	7003101	7003501	7008201	7008301
Topics:	Analyse electrical systems and check functions	x	x	x	x								
	Analyse and adjust controls						x	x					
	Ensure electricity supply and safety of equipment						x	x					
	Analyse performance of electrical machines								x				
	Select and adjust controls and regulations for electrical machines									x	x		
	Integrate electrical machinery in technical systems									x		x	x

ELECTRONICS SYSTEM TECHNICIAN

		7001101	7001201	7001301	7001401	7001501	7001601	7001701	7001801	7003101	7003601	70039	7003501	7008201
Topics:	Analyse electrical systems and check functions	x	x	x	x									
	Analyse and adjust controls							x	x					
	Design, manufacture and test electronic assemblies of equipment					x	x							
	Configure assemblies of hardware and software										x	x		x
	Produce equipment and check													x
	Set up production facilities									x	x	x	x	
	Configuring and using test systems									x	x	x		

NEW ONLINE-SHOP

THE NEW LEYBOLD ONLINE-SHOP

Comfortable search and fast navigation!



In just 2 clicks on an experiment or product



Clear and fault tolerant search



All information at a glance



We have also revised our LD DIDACTIC Group website for a more easily search for products and related information.

www.ld-didactic.com

WWW.LEYBOLD-SHOP.COM



COM3LAB

M1.1 ELECTRICAL ENGINEERING

M1.1.1 FUNDAMENTALS

- M1.1.1.1 DC Technology
- M1.1.1.2 AC Technology
- M1.1.1.3 Electrical Components
- M1.1.1.4 Digital Technology
- M1.1.1.5 Operational Amplifier
- M1.1.1.6 Three-Phase Technology
- M1.1.1.7 Measurement Technology

M1.1.2 SPECIALIZATIONS

- M1.1.2.1 Mechatronics
- M1.1.2.2 Measuring, Control, Automation
- M1.1.2.3 Drive Technology
- M1.1.2.4 Motors & Generators
- M1.1.2.5 Communication Technology
- M1.1.2.6 Communications Network
- M1.1.2.7 Radiolocation
- M1.1.2.8 RF Technology
- M1.1.2.9 Microcontroller Technology

M1.1.3 PROJECTS

- M1.1.3.1 Circuit Design
- M1.1.3.2 Digital control lines
- M1.1.3.3 Analogue control lines
- M1.1.3.4 Automation Technology
- M1.1.3.5 Power Electronics
- M1.1.3.6 Drive Technology

M1.1.1
FUNDAMENTALS

M1.1.1.1
DC Technology

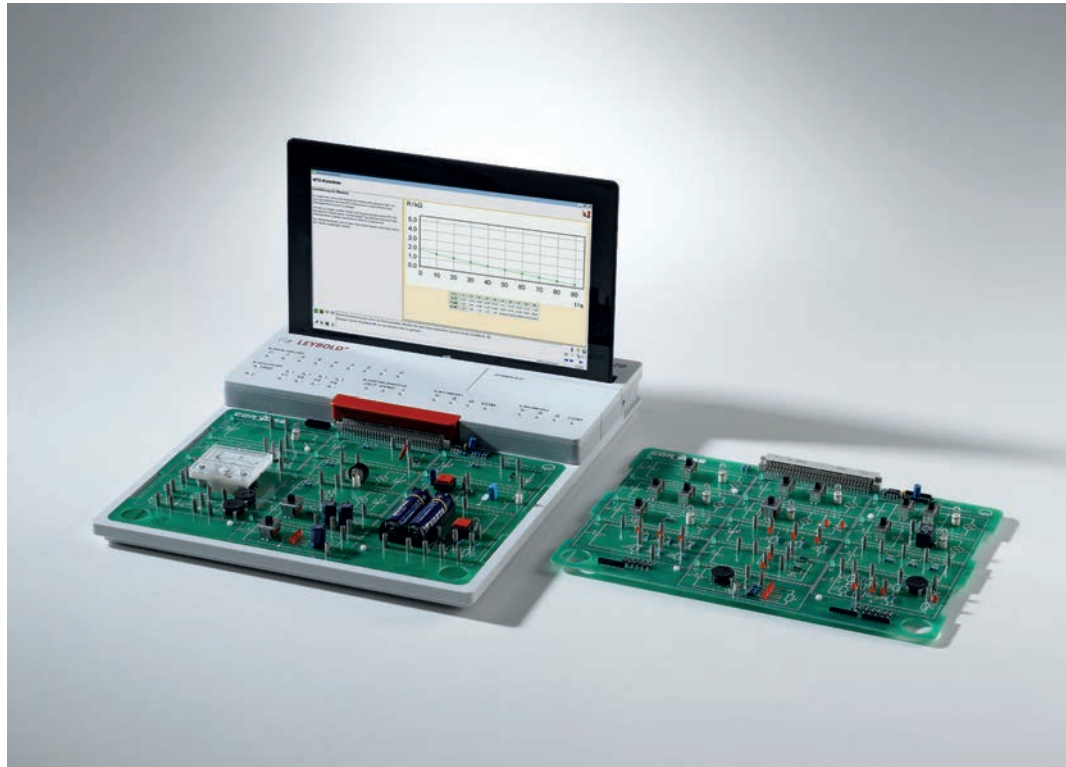
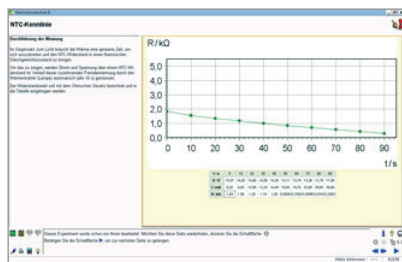

DC Technology (M1.1.1.1)

Cat. No.	Description	M1.1.1.1
700 1101	COM3LAB course: DC technology I	1
700 1201	COM3LAB course: DC technology II	1
700 020	COM3LAB Master Unit	1
700 022	Safety cable 2mm	1
700 00CBTDE	DVD: COM3LAB software, German	
700 00CBTEN	DVD: COM3LAB software, English	1
	700 00CBTXX - The COM3LAB - Software is also available in French, Dutch, Polish, Russian, Spanish, etc.	1

The courses DC Technology I + II are the beginner courses in electrical engineering. Step by step, the fundamental terms and laws of electrical engineering are explained and developed with experiments and animations.

Learning objectives

- Layout and impact of the basic circuits
- Learning the basic laws of electrical engineering
- Recording characteristic curves of passive components

DC Technology I begins with the explanation of an electric circuit. Using theoretical and practical examples, the functionality of different basic circuits is dealt with.

DC Technology II deals with the mode of operation of passive components. With the automatic recording of characteristic curves, the behaviour of the components becomes clear very quickly.

Topics*

- Basic circuits
- Basic laws
- Voltage dividers
- Wheatstone bridge
- Characteristic (incandescent lamp, VDR, Diode, NTC, etc.)
- Capacitor
- Inductance
- Batteries

* you will receive further information on the course topics in the product section!

M1.1.1 FUNDAMENTALS

M1.1.1.2 AC Technology

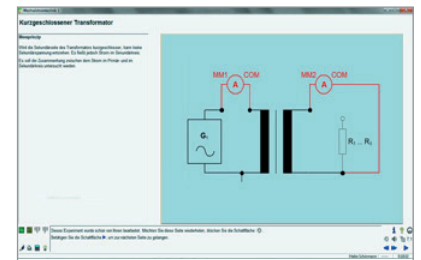
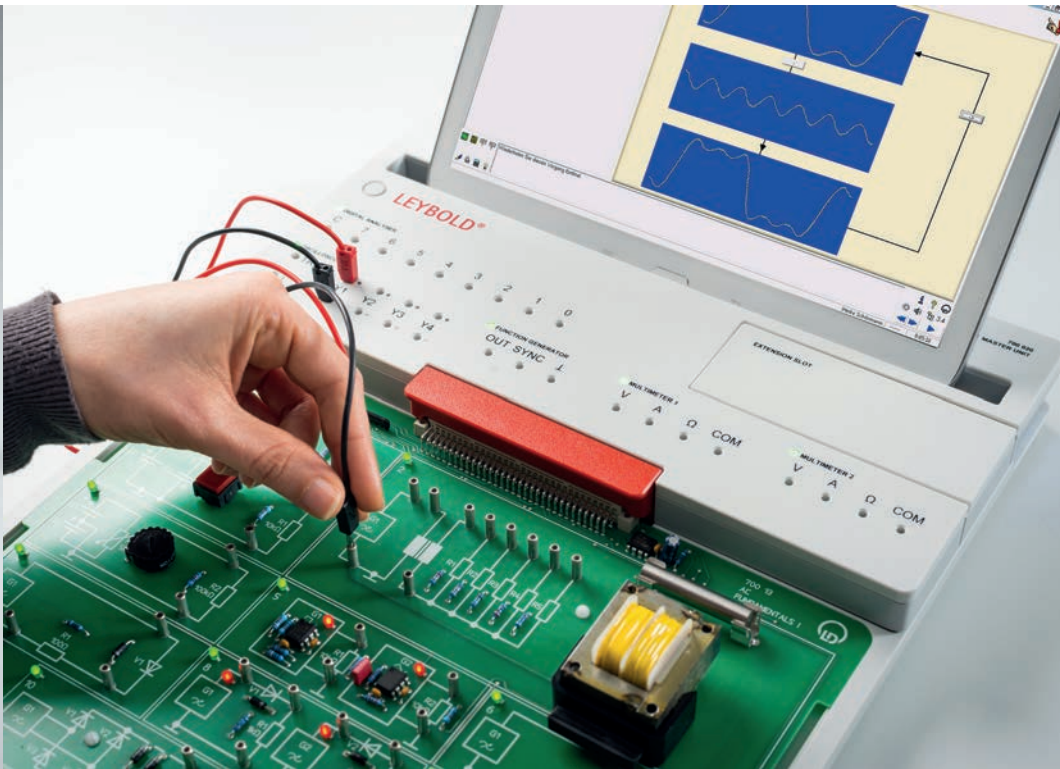

AC Technology (M1.1.1.2)

Cat. No.	Description	M1.1.1.2
700 1301	COM3LAB course: AC technology I	1
700 1401	COM3LAB course: AC technology II	1
700 020	COM3LAB Master Unit	1
700 022	Safety cable 2mm	1
700 00CBTDE	DVD: COM3LAB software, German	
700 00CBTEN	DVD: COM3LAB software, English	1
	700 00CBTXX - The COM3LAB - Software is also available in French, Dutch, Polish, Russian, Spanish, etc.	

Both courses AC technology I + II deal with the function of alternating currents and voltages.

Learning objectives

- Using function generator and oscilloscope
- Principle and function of a transformer
- Key parameters and fundamentals of the AC circuits

AC I deals with e.g. the generation of an AC voltage or the function of a transformer.

AC II deals with the behaviour of passive components in different circuits. Coil, capacitor and resistor are analysed and evaluated in different circuits.

Topics*

- Step voltage
- Continuous AC voltage
- Electronic generation of AC voltage
- Function generator and oscilloscope
- Induction
- Transformer
- Rectifier
- AC circuit (key parameters, resistor, coil)
- Series circuit (R/L, R/C, R/L/C)
- Parallel circuit (R/L, R/C, R/L/C)
- Capacitor
- Compensation
- Resonance

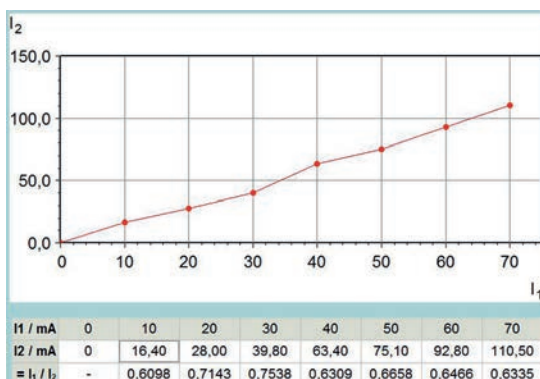

Current transformation for the short-circuited transformer

* you will receive further information on the course topics in the product section!

M1.1.1
FUNDAMENTALS

M1.1.1.3
Electrical Components

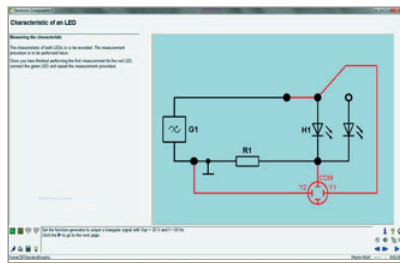
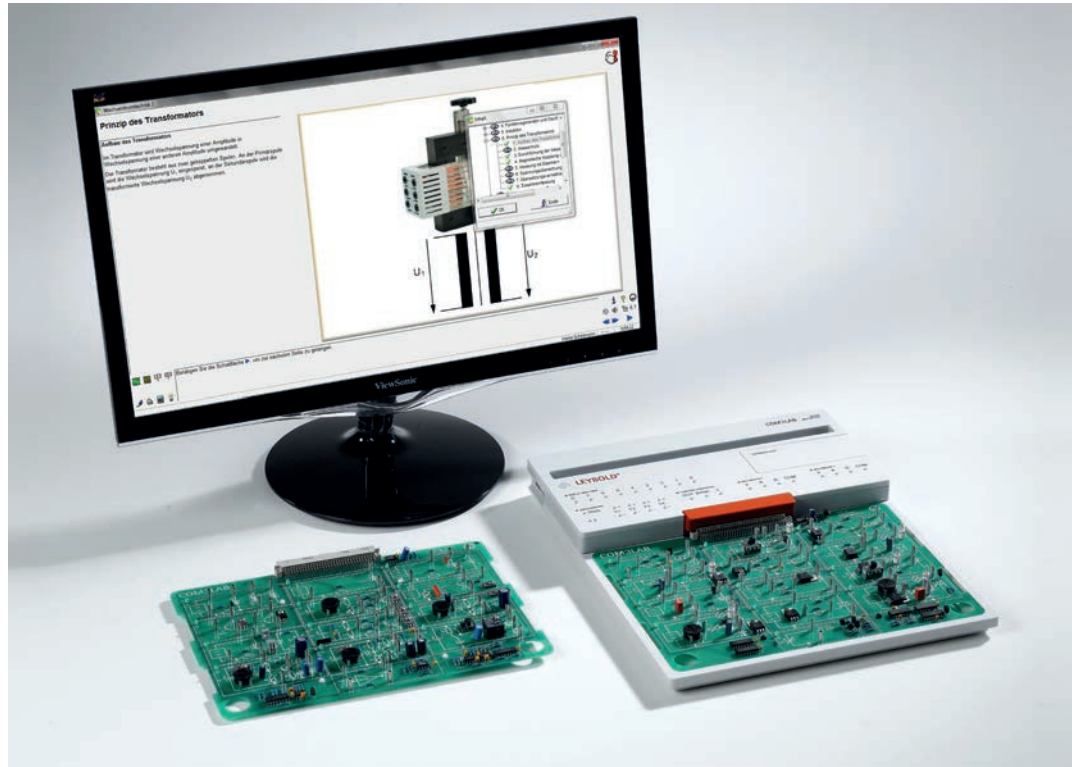

Electrical Components (M1.1.1.3)

Cat. No.	Description	M1.1.1.3
700 1501	COM3LAB Course: Electronic components I	1
700 1601	COM3LAB Course: Electronic components II	1
700 020	COM3LAB Master Unit	1
700 022	Safety cable 2mm	1
700 00CBTDE	DVD: COM3LAB software, German	
700 00CBTEN	DVD: COM3LAB software, English	1
	700 00CBTXX - The COM3LAB - Software is also available in French, Dutch, Polish, Russian, Spanish, etc.	

A wide range of components are required for electrical and electronic circuits. The courses Electronic Components I+ II focus on active components, which act intensively or enable control.

Learning objectives

- Structure, function and use of active components
- Recording the characteristics
- Standard circuits and their areas of use

In the course Electronic Components I the most important diode types are introduced. Outlet and blockage characteristics are recorded and evaluated with the two-channel memory oscilloscope. The npn and pnp transistor is examined in its functions, circuits and characteristics.

In the course Electronic Components II special transistor types and semiconductors in power electronics are used. One of their main uses, the phase controlled modulator, is examined using the example of the thyristor and the triac.

Topics*

- Characteristics (Z-diode, LED)
- Transistor: structure, function, effect
- Transistor circuits: emitter, collector, basic, Darlington
- structure, function, effect, Characteristics:
 - Field effect transistor
 - MOSFET
 - IGBT
 - DIAC
 - TRIAC

* you will receive further information on the course topics in the product section!

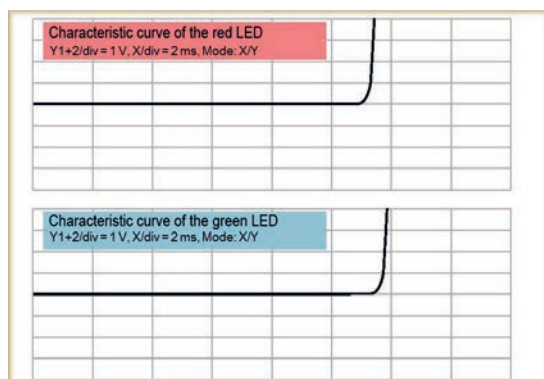

Characteristic curve of an LED

M1.1.1 FUNDAMENTALS

M1.1.1.4 Digital Technology

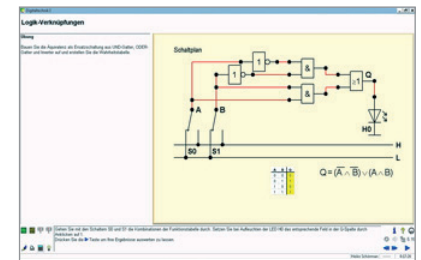
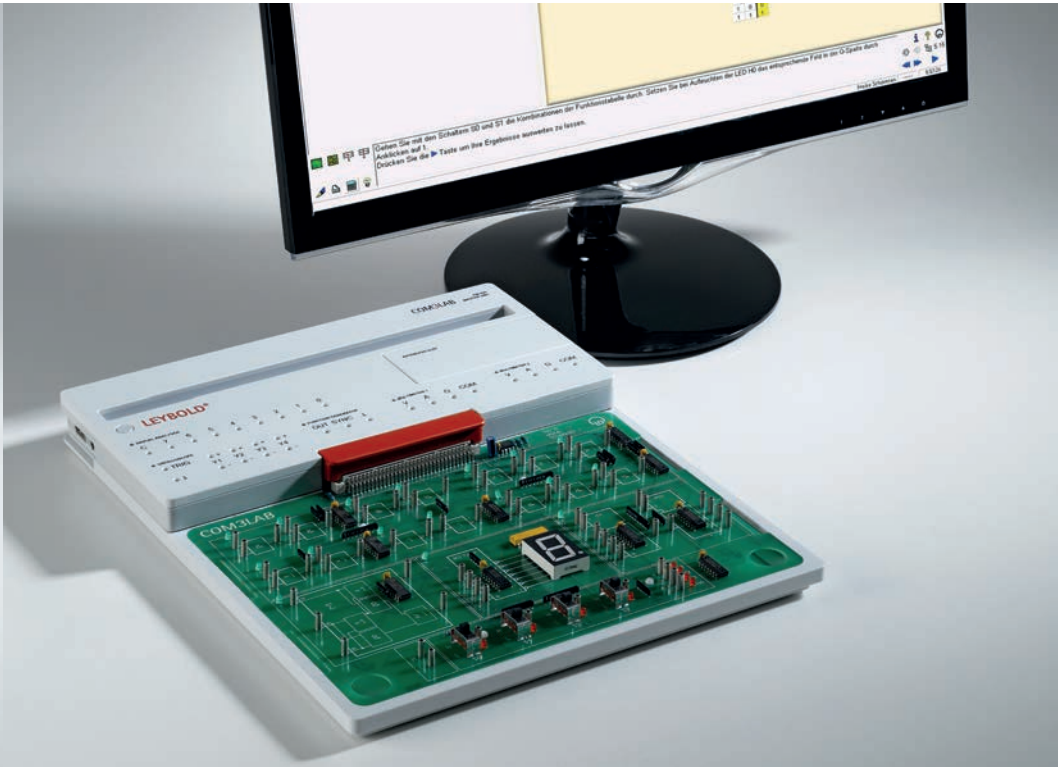

Digital Technology (M1.1.1.4)

Cat. No.	Description	M1.1.1.4
700 1701	COM3LAB course: Digital technology I	1
700 1801	COM3LAB course: Digital technology II	1
700 020	COM3LAB Master Unit	1
700 022	Safety cable 2mm	1
700 00CBTDE	DVD: COM3LAB software, German	
700 00CBTEN	DVD: COM3LAB software, English	1
	700 00CBTXX - The COM3LAB - Software is also available in French, Dutch, Polish, Russian, Spanish, etc.	

Topics*

- TTL components (AND, OR, XOR)
- Link of binary inputs
- Basic laws
- Coding
- 7-segment display
- Karnaugh map
- Full-adders
- Multiplexers
- Flip-flop (RS, JK, D)
- Binary mat
- Forward and reverse counter
- BCD counter
- Synchronous counter
- Shift register
- Parallel-serial converter

The COM3LAB courses Digital Technology I + II form the foundation for the courses Microcontroller and Telecommunications.

Learning objectives

- Structure, function and effect of the individual logic elements
- Learning important laws of propositional logic
- Use of the TTL components in application circuits

In the course Digital technology I the bases and laws of switch algebra are dealt with using logic links.

In the course Digital Technology I various flip-flop applications, e.g. shift registers, parallel-serial converters or the serial data transmission are dealt with. Both courses deal extensively with troubleshooting.

* you will receive further information on the course topics in the product section!

M1.1.1
FUNDAMENTALS

M1.1.1.5
Operational Amplifier

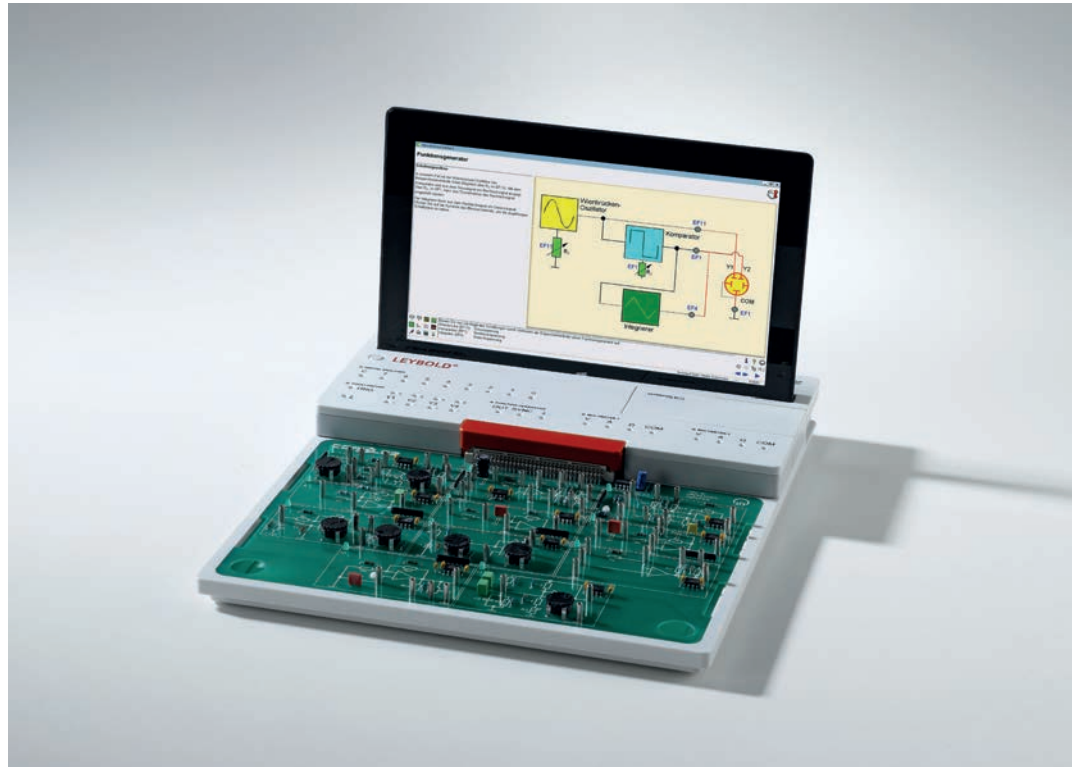
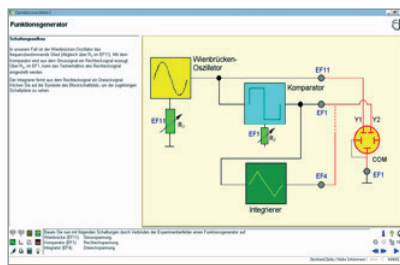

Operational Amplifier (M1.1.1.5)

Cat. No.	Description	M1.1.1.5
700 8101	COM3LAB Course: Operational amplifier	1
700 020	COM3LAB Master Unit	1
700 022	Safety cable 2mm	1
700 00CBTDE	DVD: COM3LAB software, German	
700 00CBTEN	DVD: COM3LAB software, English	1
	700 00CBTXX - The COM3LAB - Software is also available in French, Dutch, Polish, Russian, Spanish, etc.	

This course gives you insight into the world of the operational amplifier. From the standard circuit to the implementation of a function generator, all important topic areas are dealt with. This course forms the basis for the courses of control technology.

Learning objectives

- Features and function of operational amplifier
- Use and application of operational amplifier

Topics

- Comparator
- Features of the operational amplifier
- Inverting operational amplifier
- Noninverting operational amplifier
- Fault simulation in the inverting operational amplifier
- Adder
- Integrator
- Differentiator
- Active filters
- Constant voltage source
- Constant current source
- Schmitt trigger
- Astable multivibrator
- Wien bridge oscillator
- Function generator

M1.1.1 FUNDAMENTALS

M1.1.1.6 Three-Phase Technology

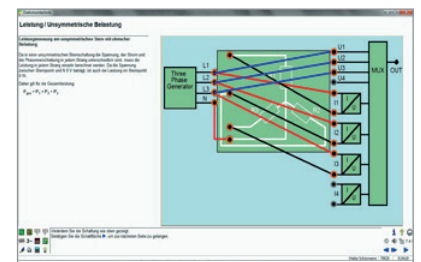
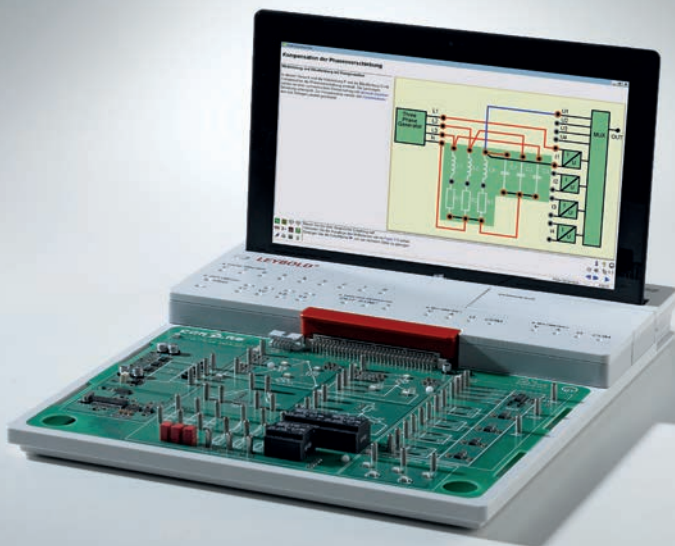

Three-Phase Technology (M1.1.1.6)

Cat. No.	Description	M1.1.1.6
700 2401	COM3LAB course: Three-Phase technology	1
700 020	COM3LAB Master Unit	1
700 022	Safety cable 2mm	1
700 00CBTDE	DVD: COM3LAB software, German	
700 00CBTEN	DVD: COM3LAB software, English	1
	700 00CBTXX - The COM3LAB - Software is also available in French, Dutch, Polish, Russian, Spanish, etc.	

The COM3LAB course "Three-phase technology" deals with the bases and key parameters of three-phase current. A three-phase generator enables practical experimentation. The differences between a star and a delta circuit are analysed in various tests. Currents, voltages and outputs are measured with symmetrical and unsymmetrical load. An oscilloscope with 8 channels enables phase and line voltages / currents to be shown at the same time.

Learning objectives

- Using three-phase current

Topics*

- Key parameters of three-phase technology
- Star and triangular symmetrical load
- Star and triangular unsymmetrical load
- Power measurement
- Compensation of the phase shift
- Connection of a three-phase motor
- Rotary field measuring instrument

* you will receive further information on the course topics in the product section!

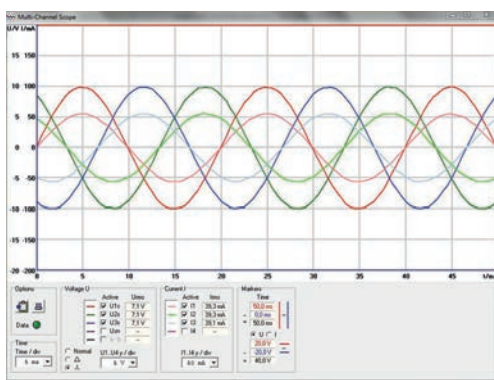

Power measurement at the unsymmetrical star with resistive load

M1.1.1
FUNDAMENTALS

M1.1.1.7
Measurement Technology

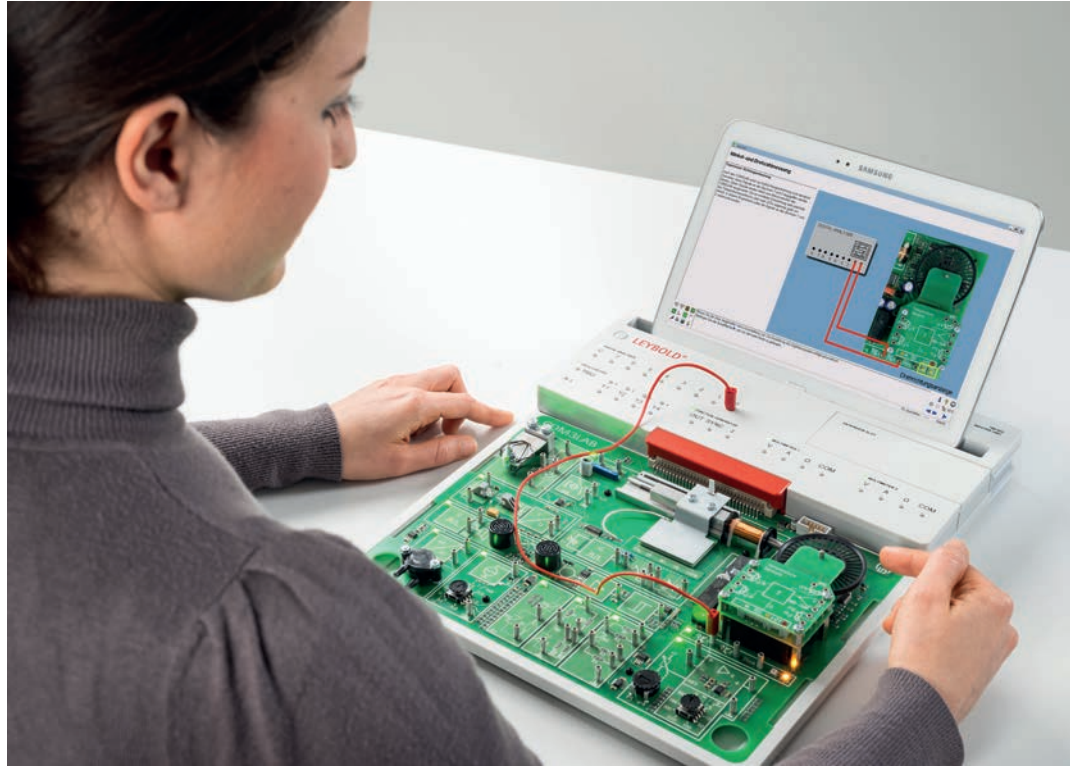
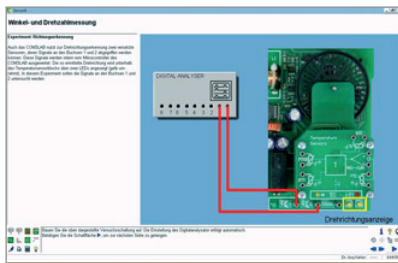

Measurement Technology (M1.1.1.7)

Cat. No.	Description	M1.1.1.7
700 8401	COM3LAB Course: Sensor technology	1
700 020	COM3LAB Master Unit	1
700 022	Safety cable 2mm	1
700 00CBTDE	DVD: COM3LAB software, German	
700 00CBTEN	DVD: COM3LAB software, English	1
	700 00CBTXX - The COM3LAB - Software is also available in French, Dutch, Polish, Russian, Spanish, etc.	

The COM3LAB course "Sensor Technology" teaches the basics of measuring non-electric quantities. With many examples, explanations, exercises and practical tasks, the principles and the function of the sensors and the associated measuring circuits are clearly illustrated.

Learning objectives

- Measuring non-electric quantities
- Function of the sensors

Topics*

- Measuring circuits for measuring temperature
- Effect and characteristics of different temperature sensors: Pt 100, NTC, KTY and thermocouple
- Effect and characteristics of pressure sensors
- Force measurement with strain gauges
- Force measurement with bending bar and torsion bar
- Displacement-, angle- and speed measurement
- Resolver measurements
- Hall sensors
- Ultrasound

* you will receive further information on the course topics in the product section!

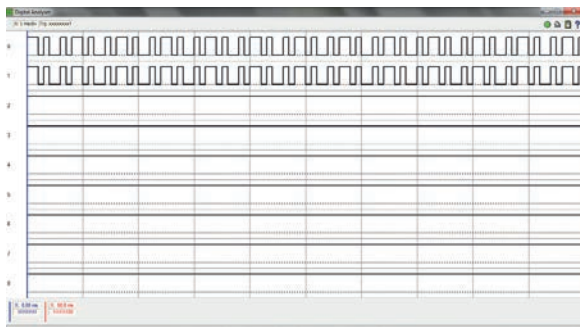

Speed measurement

M1.1.2 SPECIALIZATIONS

M1.1.2.1 Mechatronics

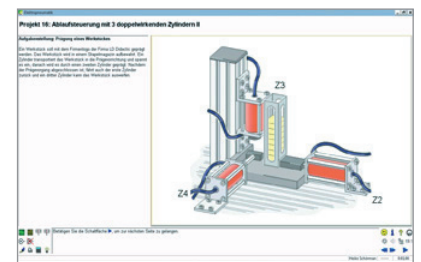
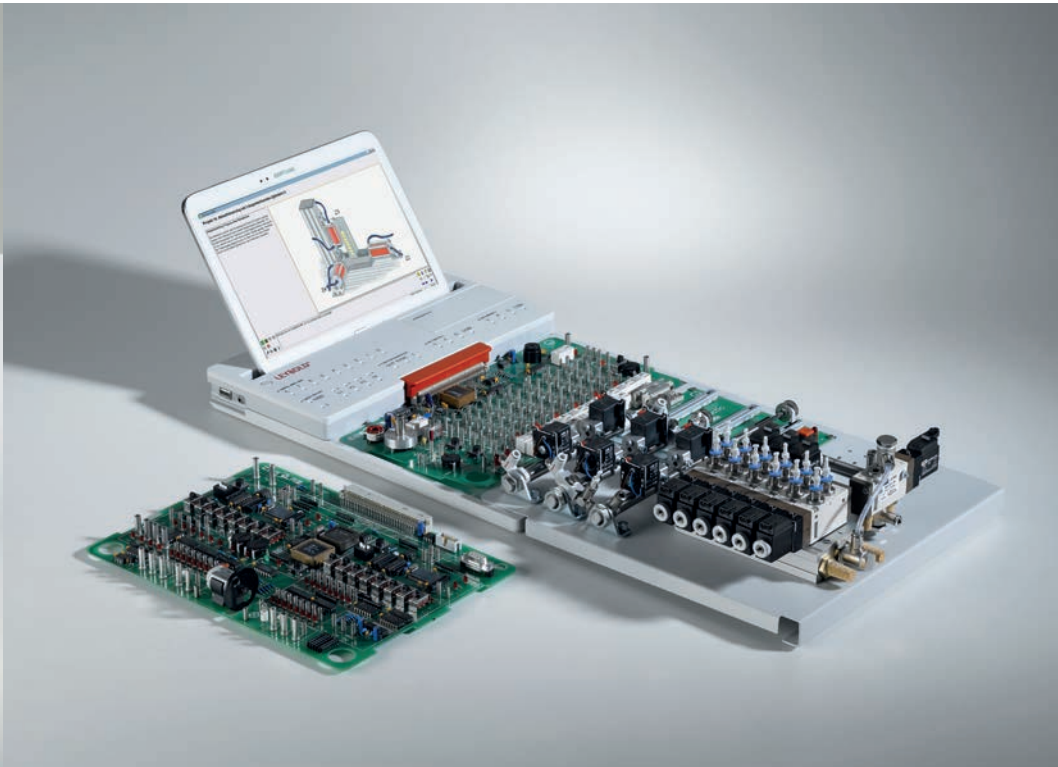

Mechatronics (M1.1.2.1)

Cat. No.	Description	M1.1.2.1
700 3501	COM3LAB Course: Electropneumatics	1
700 351	COM3LAB Course: Pneumatics Board	1
700 3101	COM3LAB Course: Automation and bus technology	1
700 020	COM3LAB Master Unit	1
700 022	Safety cable 2mm	1
700 00CBTDE	DVD: COM3LAB software, German	
700 00CBTEN	DVD: COM3LAB software, English	1
744 902	Compressor Connection Hosing	1*
744 600	Low Noise Compressor	1*
	700 00CBTXX - The COM3LAB - Software is also available in French, Dutch, Polish, Russian, Spanish, etc.	

* additionally required

In the field of mechatronics signals and information are automatically detected, processed and transformed into force and movement. Everyday life today would be unimaginable without mechatronic products and they are found e.g. in cars, DVD players, air planes etc. The COM3LAB courses Electropneumatics and Automation technology together provide an extensive training package, which covers both the electrical and mechanical topics.

Learning objectives

- Learning physical basic principles
- Independent formulation of development projects
- Planning, repair and execution of complete process cycles

The COM3LAB course Electropneumatics teaches the basics of electro-pneumatics using the BIBB standard tasks. The COM3LAB course Automation technology explains the function and application of a PLC. Several examples make it easy to learn the PLC computer language.

Both courses can be combined so that complete process cycles can be executed and documented. This kind of project work supports independent and creative handling.

Topics*

- Function and use of electronic and pneumatic components
- Electronic and pneumatic schematics
- Various standard circuits
- Function and use of a PLC
- Programming
- Bus systems

* you will receive further information on the course topics in the product section!

M1.1.2
SPECIALIZATIONS

M1.1.2.2
Measuring, Control, Automation

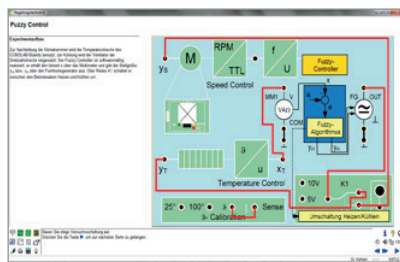

Measuring, Control, Automation (M1.1.2.2)

Cat. No.	Description	M1.1.2.2
700 8101	COM3LAB Course: Operational amplifier	1
700 8201	COM3LAB course: Control technology I	1
700 83	COM3LAB course: Control technology II	1
700 8401	COM3LAB Course: Sensor technology	1
700 3101	COM3LAB Course: Automation and bus technology	1
700 020	COM3LAB Master Unit	1
700 022	Safety cable 2mm	1
700 00CBTDE	DVD: COM3LAB software, German	
700 00CBTEN	DVD: COM3LAB software, English	1
	700 00CBTXX - The COM3LAB - Software is also available in French, Dutch, Polish, Russian, Spanish, etc.	

Measure, Actuate and Control (MSR) are terms from the field of automation. The objective is to monitor and run technical processes and production procedures through automatic control systems. Fast-spreading automation today requires profound knowledge of sensors and how to use control loops in many qualified occupations.

The MSR COM3LAB courses take this development into account. They teach applied knowledge of the measurement, actuation and control technology vividly and in detail.

Learning objectives

- Measuring non-electric quantities
- Good knowledge in the topics of operational amplifiers and sensor technology
- Good understanding of electronic control loops
- Programming and planning of a PLC

Topics*

- Operational amplifier
- Control technology
- Sensor technology
- Automation technology

* you will receive further information on the course topics in the product section!

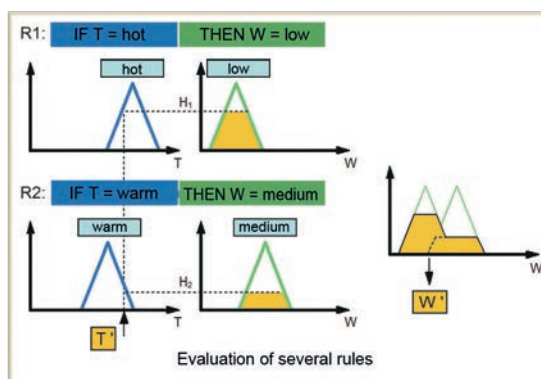

FUZZY control

M1.1.2 SPECIALIZATIONS

M1.1.2.3 Drive Technology

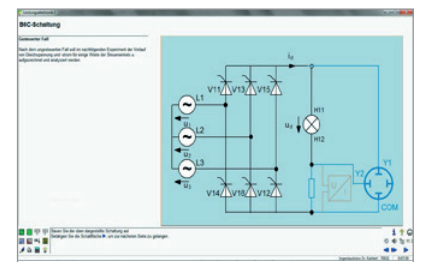
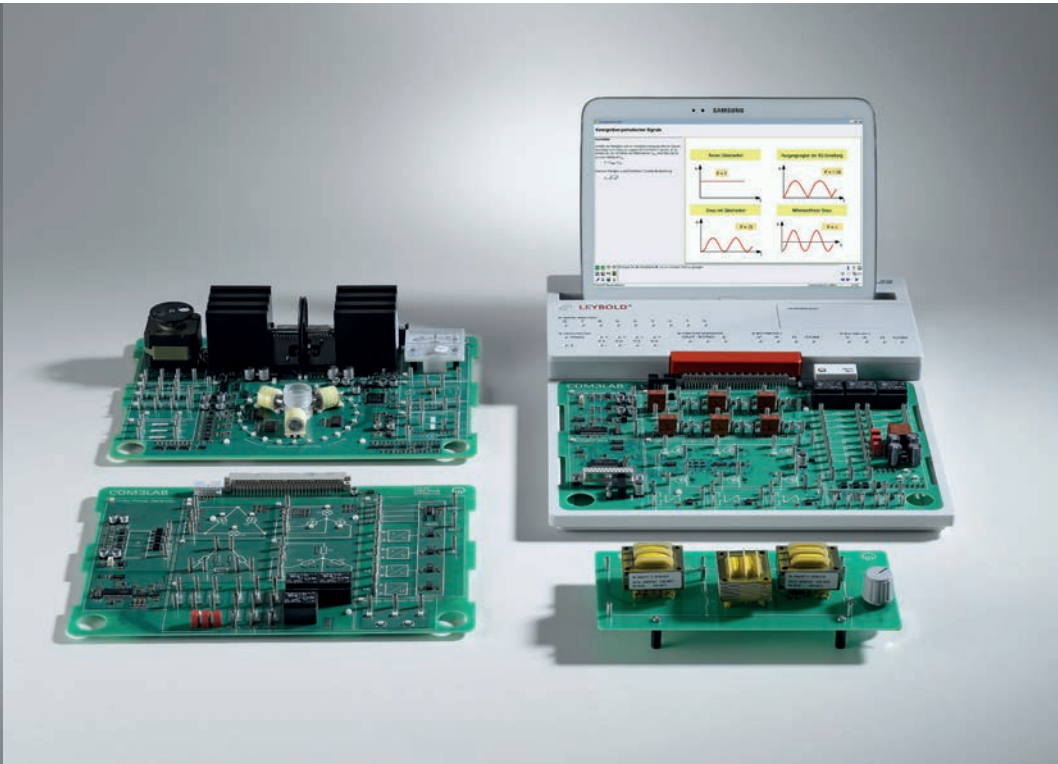

Drive Technology (M1.1.2.3)

Cat. No.	Description	M1.1.2.3
700 2101	COM3LAB course: Power electronics I	1
700 22	COM3LAB course: Power electronics II	1
700 2401	COM3LAB course: Three-phase technology	1
700 2501	COM3LAB course: Electrical machines I	1
700 020	COM3LAB Master Unit	1
700 022	Safety cable 2mm	1
700 00CBTDE	DVD: COM3LAB software, German	
700 00CBTEN	DVD: COM3LAB software, English	1
	700 00CBTXX - The COM3LAB - Software is also available in French, Dutch, Polish, Russian, Spanish, etc.	

The drive technology is an application which focuses on modern power electronics. Using power electronics, speed-variable DC and three-phase four-quadrant drives can be easily implemented. Nowadays drive technology would not be imaginable without thyristor speed control units, soft-start circuits, frequency converters, servo drives etc. in industry, trade, commercial companies and households.

With the COM3LAB courses on power electronics and drive technology, the specialist knowledge can be gained graphically, both theoretically and practically.

Learning objectives

- Recognizing physical basic principles
- Structure of important base circuits
- Recording machine characteristics
- Introduction to drive technology

Topics*

- Three-phase current
- Characteristics and use of power semiconductors
- Features of commutator - / three-phase machines and stepper motors
- Recording of characteristics of the most important machines

*you will receive further information on the course topics in the product section!

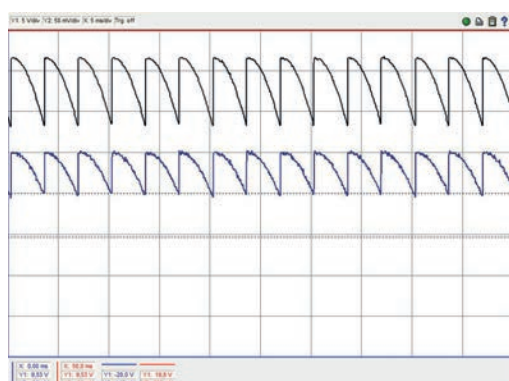

B6C - circuit: Controlled case

M1.1.2
SPECIALIZATIONS

M1.1.2.4
Motors and Generators

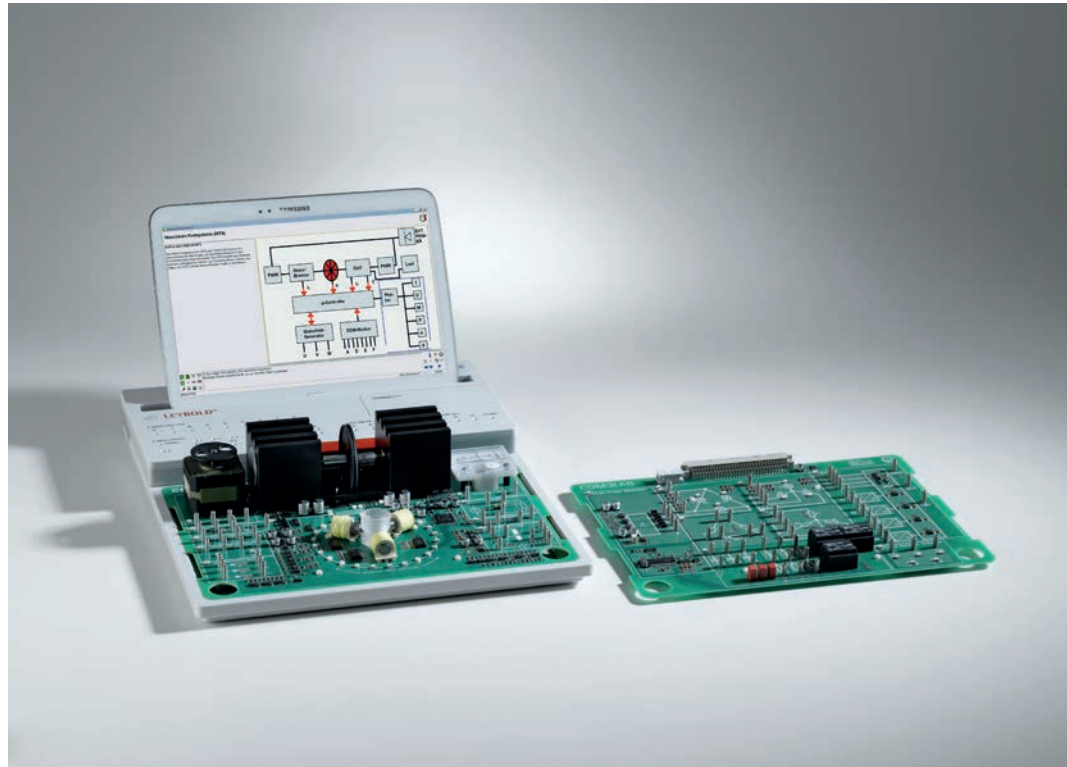
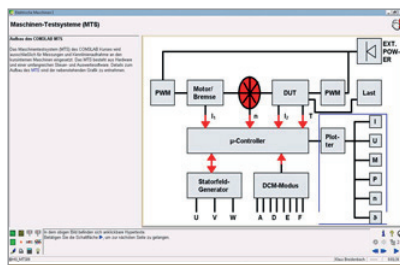

Motors and Generators (M1.1.2.4)

Cat. No.	Description	M1.1.2.4
700 2401	COM3LAB course: Three-phase technology	1
700 2501	COM3LAB course: Electrical machines I	1
700 020	COM3LAB Master Unit	1
700 022	Safety cable 2mm	1
700 00CBTDE	DVD: COM3LAB software, German	
700 00CBTEN	DVD: COM3LAB software, English	1
	700 00CBTXX - The COM3LAB - Software is also available in French, Dutch, Polish, Russian, Spanish, etc.	

The COM3LAB courses Electrical machines and Three-phase technology lead you through the fascinating world of electrical motors and generators.

Learning objectives

- Recognizing physical basic principles
- Recording of machine characteristics
- Introduction to drive technology

With the COM3LAB course Three-phase technology the special features of multiphase networks are discussed. It forms the basis for understanding rotary field machines like asynchronous and synchronous machines.

Topics*

- Key parameters of the three-phase current
- Base circuits
- Applications

In the COM3LAB course Electrical machines the features of commutator machines, rotary field machines and stepper motors are developed in demanding experiments. Among other things, the course board contains a complete machine test system with which the characteristics of the most important machines are examined.

Topics*

- Machine test system
- DC machines
- Synchronous machines
- Asynchronous machines
- Recording of characteristics
- Speed adjustment

* you will receive further information on the course topics in the product section!

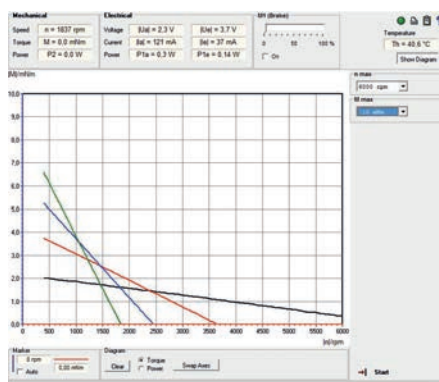

Characteristic curve of a separately excited DC machine

M1.1.2 SPECIALIZATIONS

M1.1.2.5 Communication Technology



Communication Technology (M1.1.2.5)

Cat. No.	Description	M1.1.2.5
700 7101	COM3LAB Course: Transmission Technology TX433	1
700 7201	COM3LAB Course: Reception Technology RX433	1
700 7301	COM3LAB Course: Digital Communication Technology	1
700 7401	COM3LAB Course: Modem Technology	1
700 7501	COM3LAB Course: Telecommunication Lines	1
700 020	COM3LAB Master Unit	1
700 022	Safety cable 2mm	1
700 00CBTDE	DVD: COM3LAB software, German	
700 00CBTEN	DVD: COM3LAB software, English	1
	700 00CBTXX - The COM3LAB - Software is also available in French, Dutch, Polish, Russian, Spanish, etc.	

The electrical communications technology mainly deals with information transmission using signals. Without communications technology there would be no internet and no mobile phones today. The communications technology occupations deal with the fields of high frequency technology, transmission technology and wiring technology.

The COM3LAB courses of communications technology teach the knowledge clearly and application-oriented using modulation, the various transmission methods, coding, line links, services, logs etc.

Learning objectives

- Learning physical basic principles
- Knowledge of various transmission methods
- Independent application and planning of transmission media

Topics*

- Conception and the operating characteristics of modern data – and radio stations
- Applications of PCM Codecs in the voice – and signal transmission
- Classic shift keying also QPSK and the procedures MSK and GSMK used in the area of mobile radio
- Fault response of shift keying
- Function and use of two- / four-wire lines, coaxial cables, fibre optic lines etc.

* you will receive further information on the course topics in the product section!

M1.1.2

SPECIALIZATIONS

M1.1.2.6

Communications Networks

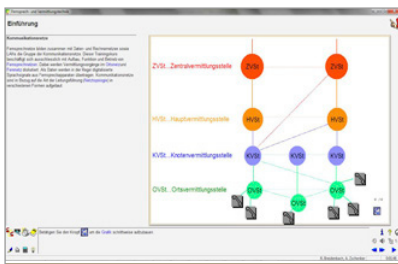

Communications Networks (M1.1.2.6)

Cat. No.	Description	M1.1.2.6
700 7401	COM3LAB Course: Modem Technology	1
700 7501	COM3LAB Course: Telecommunication Lines	1
735 800	COM3LAB Course: Foundations of Local & Trunk Exchange Systems	1

Communication networks describe the infrastructure for transmitting information in communications technology. For this reason, communication systems establish communication links between several terminals.

With the COM3LAB courses Communication networks the communication systems can be reproduced, projected and analysed.

Learning objectives

- Learning physical basic principles
- Knowledge of various transmission methods
- Independent application and projecting of transmission media
- Independent projecting and analysis of communications systems

Topics*

- Classic keying methods also QPSK and the procedures MSK and GSMK used in the area of mobile radio
- Fault response of shift keying
- Function and use of two- / four-wire lines, coaxial cables, fibre optic lines etc.
- Telecommunications – and switching technology in the local and long-distance network
- Voice signal coding

* you will receive further information on the course topics in the product section!

M1.1.2 SPECIALIZATIONS

M1.1.2.7 Radiolocation

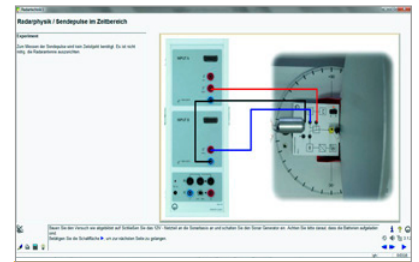

Radiolocation (M1.1.2.7)

Cat. No.	Description	M1.1.2.7
737 60	COM3LAB Course: Radar Technology I	1
737 65	COM3LAB Course: Radar Technology II	1

The radar technology is a radio location procedure which identifies cooperative and noncooperative targets with echo procedures. Equipped with unique capabilities, such as independence on weather – and daylight, wide range, high measuring insensitivity etc., it is now hard to imagine the world without radar technology in military and civil applications.

The COM3LAB Radar technology courses take these high demands into account. They enable realistic experiments on radar technology in the laboratory.

Learning objectives

- Learning physical basic principles
- Function and structure of a radar
- Evaluation of a radar

The COM3LAB course Radar technology I works with a monostatic ultrasonic radar.

The COM3LAB course Radar technology II works with an X-band microwave source. It examines the principles and applications of the Doppler effect by measurements in the time and frequency domain (FFT analysis of the Doppler spectrum in the base tape).

Topics*

- Distance measurement
- Echo representation
- Delay measurements
- Radar cross sections
- Tracking
- Target suppression
- Representation of mobile targets
- Detection of noncooperative / cooperative targets and stealth

* you will receive further information on the course topics in the product section!

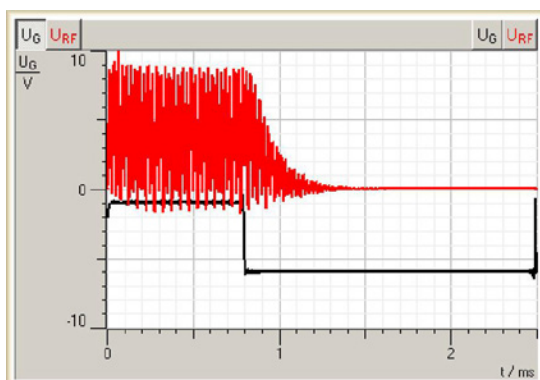

Radar physics / transmitted pulses in the time domain

M1.1.2

SPECIALIZATIONS

M1.1.2.8

RF technology

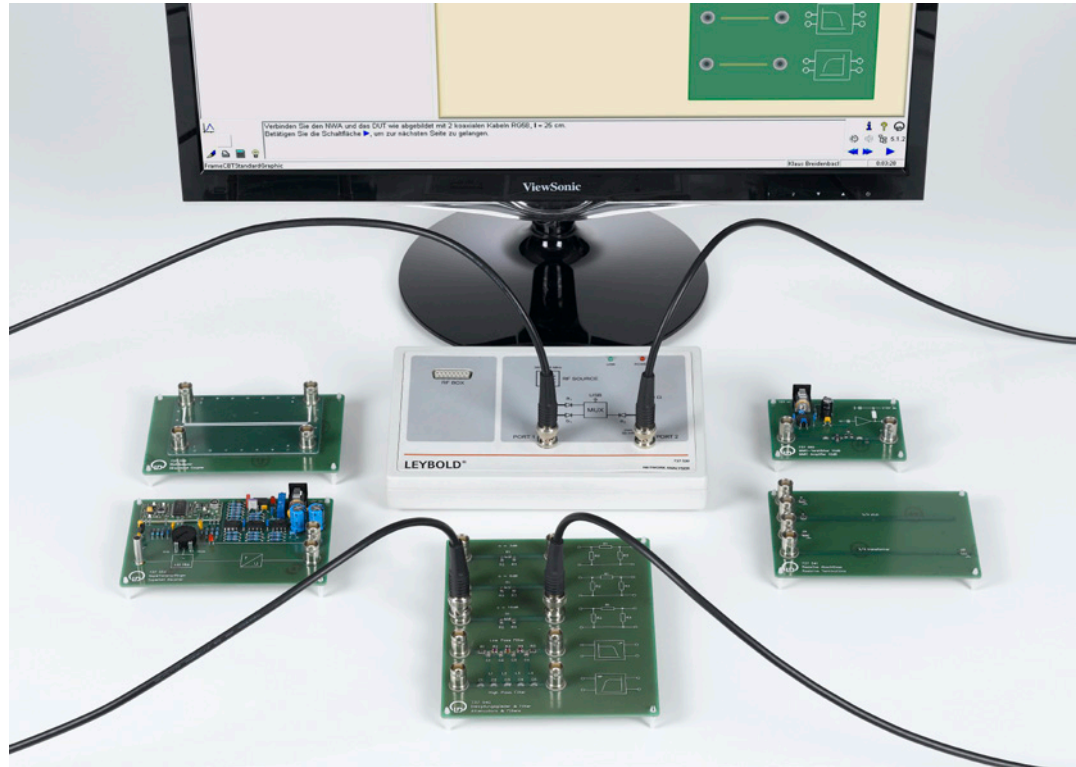
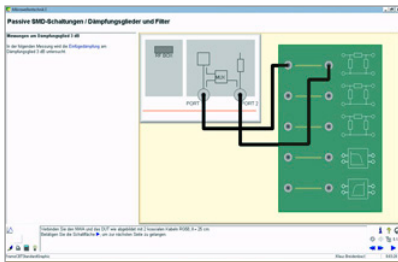

RF technology (M1.1.2.8)

Cat. No.	Description	M1.1.2.8
737 51	COM3LAB Course: Microwave Technology I	1
737 52	COM3LAB Course: Microwave Technology II	1
737 60	COM3LAB Course: Radar Technology I	1
737 65	COM3LAB Course: Radar Technology II	1

- Knowledge of the transmission methods
- Function and structure of a radar
- Evaluation of a radar screen

The COM3LAB Microwave technology courses work with a vector network analyser and have integrated evaluation functions. The evaluations are shown in a Smith diagram and Bode plot.

Topics*

- Vector network analysis
- Measurements on the measuring line
- Passive UHF circuits in microstrip loop and SMD technology
- Active microwave components

Global communication and mass transport on the street or in the air require efficient RF systems. Mobile radio networks, satellite communication, traffic control, air traffic safety, navigation services, GPS, etc. are applications which critically depend on the fault-free operation of their RF components.

The COM3LAB courses Microwave technology and Radar technology teach application-oriented knowledge on RF technology clearly and in detail.

Learning objectives

- Learning physical basic principles
- Independent use of network analysers, Smith chart and Bode plot
- Independent analysis of microwave circuits

The COM3LAB Radar technology courses examine the function and applications of modern primary and secondary radars experimentally. From the civil air traffic safety and the air surveillance with friend / foe recognition (IFF) to the coast radar and the security services, all topics are dealt with through of interesting tests.

Topics*

- Physical principles of radar technology
- Technical implementation of radar systems
- Tactical tests with radars.

* you will receive further information on the course topics in the product section!

M1.1.3
PROJECTS

M1.1.3.1
Circuit Design

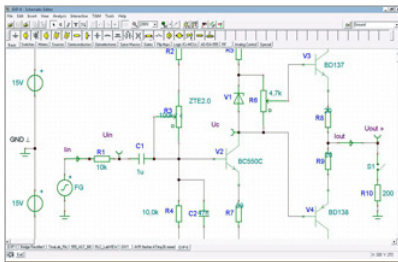

Circuit Design (M1.1.3.1)

Cat. No.	Description	M1.1.3.1
700 905	COM3LAB TT: AMPLIFIER CIRCUITS	1
700 908	COM3LAB TT: POWER SUPPLY CIRCUITS	1
700 9101	COM3LAB Protoboard II	1
700 020	COM3LAB Master Unit	1
700 022	Safety cable 2mm	1
700 00CBTDE	DVD: COM3LAB software, German	
700 00CBTEN	DVD: COM3LAB software, English	1
700 901-01	Electina Standard, COM3LAB support (1 license), german	
700 901-11	Electina Design Suite, PCB, COM3LAB support (1 license), german	
700 902-01	Electina Standard, COM3LAB support (1 license), English	1
700 902-11	Electina Design Suite, PCB, COM3LAB Support (1 licence), English	
	700 00CBTXX - The COM3LAB - Software is also available in French, Dutch, Polish, Russian, Spanish, etc.	1

Learning objectives

- Independent development of a project
- Circuit design
- Analysis
- Troubleshooting
- Circuit design
- Boosting of personal decision-making and responsibility

The subject-specific modules Amplifier circuits and power supply circuits are complete projects, which the students can either work on independently or on instruction. The subject-specific modules contain all required electronic components.

Amplifier circuits

- Single-stage amplifier using an emitter-base circuit
- Bootstrap circuit
- Darlington circuits
- Two-stage, capacitively coupled amplifier
- Two-stage, directly coupled amplifier
- Amplifier with negative feedback
- Differential amplifier
- Push-pull output stage
- Barrier junction-FET in various base circuits

Power supply circuits

- Voltage regulation with Z diode
- Voltage regulation with Z diode and parallel transistor
- Voltage regulation with Z diode and series transistor
- Power supply with adjustable voltage and adjustable current limiting

The COM3LAB Protoboard and Electina form the ideal means for carrying out project work. Schoolchildren and students receive a task and must solve it from A to Z as in their later professional life. This is a good opportunity for checking how schoolchildren implement their knowledge and where certain skills are still lacking.

The project work encourages the schoolchildren's motivation. They learn how to deal with a problem independently and solve it successfully.

M1.1.3 PROJECTS

M1.1.3.2 Digital control lines

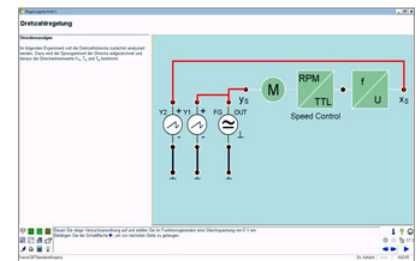

Digital control lines (M1.1.3.2)

Cat. No.	Description	M1.1.3.2
700 8201	COM3LAB course: Control technology I	1
700 83	COM3LAB course: Control technology II	1
700 020	COM3LAB Master Unit	1
700 022	Safety cable 2mm	1
700 00CBTDE	DVD: COM3LAB software, German	
700 00CBTEN	DVD: COM3LAB software, English	1
500 851	Safety connecting leads, 32 A, set of 32	1
501 511	Set of 10 bridging plugs, black	1
568 221	LIT: Fundamentals of Automatic Control Technology II, Vol. 2	1
726 09	Panel frame T130, two-level	1
726 86	Stabilised power supply ± 15 V/3 A	1
734 111	Set of machines 10 W	1
734 121	Digital Temperature Controlled System	1
734 265	Digital Liquid Control System	1
775 680EN	LIT: T8.2.1.1 Temperature Control	1
775 685EN	LIT: T8.2.1.6 Drive Control	1
	700 00CBTXX - The COM3LAB - Software is also available in French, Dutch, Polish, Russian, Spanish, etc.	1

The equipment includes the COM3LAB Control technology courses and the digital controlled systems Set of machines 10W, digital temperature – and Liquid control system.

The courses COM3LAB control technology offer extensive analysis tools and setting options and enable an optimum parameterization of the controller.

Learning objectives

- Structure of control loops
- Analysis of controlled systems
- Independent evaluation of the measuring results

Liquid control system*

In this project the liquid level measurement is used in order to maintain a pre-selectable filling level height with a control loop. In the process the filling level is controlled by the digital controller of the COM3LAB control technology. The system is very clear and shows the interplay of reference and actual value on closed control loops in didactic form. Filling level and flow can both be examined on one unit.

Temperature controlled system*

The task is to control the precisely defined temperature profiles for the casting metal in its housing, in order to keep it constant. These temperature profiles are set by using the thermally quick temperature control system. The good control dynamics shorten the measuring time. The temperature control system can be actively cooled via the COM3LAB control technology and the control behaviour can be analysed using switchable disturbance variables.

Set of machines*

With the course COM3LAB control technology, the output voltage of the generator is kept constant even when changing the load. The set of machines used here enables a multitude of experiments to be carried out. With the virtual laboratory of COM3LAB, the step response of the system can be recorded, the optimum control parameters identified or time line diagrams of the controlled system recorded.

* you will receive further information on the course topics in the product section!

M1.1.3
PROJECTS

M1.1.3.3
Analogue control lines

Cat. No.	Description	Quantity
73191	Nebenschlussmaschine 0.3 kW	1
73422	Stufiger 115...230 V/1 kW	1
73109	Tachogenerator 0.1/0.3	1
73419	Karbonsensoren	1
72686	Stab. Netzger. ±15 V/3 A	1
73106	Kopplung 0.1/0.3	1
73107	Wellenschutz 0.1/0.3	1
73108	Kopplungsschutz 0.1/0.3	1
72609	Frontkasten T130	1
500851	32 Sicher.-Er.-Kabel	1
500852	10 Sicher.-Er.-Kabel gr/vgr	1
501511	10 Verbindungsstecker sw.	1
500811	Buch Nebenschluss 0.3	1



Analogue control lines (M1.1.3.3)

Cat. No.	Description	M1.1.3.3
700 8201	COM3LAB course: Control technology I	1
700 83	COM3LAB course: Control technology II	1
700 020	COM3LAB Master Unit	1
700 022	Safety cable 2mm	1
700 00CBTDE	DVD: COM3LAB software, German	
700 00CBTEN	DVD: COM3LAB software, English	1
731 91	Shunt wound machine 0.3	1
731 09	Tacho generator 0.3	1
731 06	Coupling 0.3	1
731 07	Shaft end guard 0.3	1
731 08	Coupling guard 0.3	1
734 22	Actuator, 115...230 V/1 kW	1
734 19	Gain and offset adjust	1
726 86	Stabilised power supply ±15 V/3 A	1
500 851	Safety connecting leads, 32 A, set of 32	1
500 852	Safety connecting leads, 32 A, yellow/green, set of 10	1
501 511	Set of 10 bridging plugs, black	1
726 09	Panel frame T130, two-level	1
775 190DE	LIT: E2.2.2.0 DC Machines 0.3 (German)	
775 190EN	LIT: E2.2.2.0 DC Machines 0.3 (English)	1
	700 00CBTXX - The COM3LAB - Software is also available in French, Dutch, Polish, Russian, Spanish, etc.	1

With the COM3LAB Control technology course the speed control of a 300 W shunt wound machine is implemented. The digital controller is configured as a PID controller for this. The key parameters of control systems are measured and the dimensions of closed control loops experimentally illustrated.

Learning objectives

- Structure of control loops
- Analysis of control systems
- Independent evaluation of measuring results

The COM3LAB courses Control technology I + II are multimedia courses with a complete introduction to theory and practice. Experiments are carried out both on electronic control systems and on technical systems (light, speed and temperature control system).

An analog controller and a digital controller are available. Tests on frequency responses, nonlinear control and FUZZY control are also integrated in the continuing course II, an ideal course for a more in-depth introduction to the world of control technology.

Topics*

- Principles
- Control of technical systems
- Control of electronic systems
- Analog controller
- Digital controller
- FUZZY control

* you will receive further information on the course topics in the product section!

M1.1.3 PROJECTS

M1.1.3.4 Automation Technology

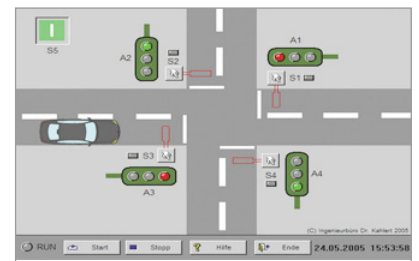
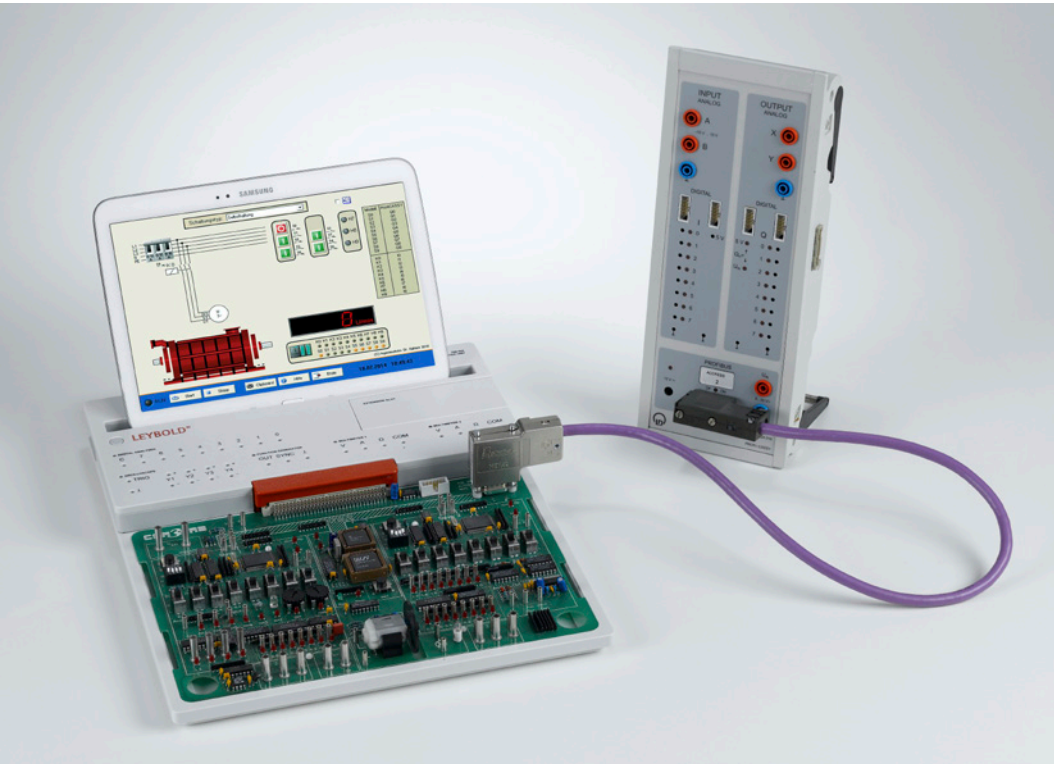

Automation Technology (M1.1.3.4)

Cat. No.	Description	M1.1.3.4
700 3101	COM3LAB Course: Automation and bus technology	1
700 020	COM3LAB Master Unit	1
700 022	Safety cable 2mm	1
700 00CBTDE	DVD: COM3LAB software, German	
700 00CBTEN	DVD: COM3LAB software, English	1
728 871	Software: 5 Modells CBS 9 (single user)	1
728 872	Software: 5 Modells CBS 9 (licence for 25 places)	1
730 4313	Bus connecting plug RS 485	1
524 016S2	PROFI-CASSY Starter 2	1
730 4312	Profibus cable	1
	700 00CBTXX - The COM3LAB - Software is also available in French, Dutch, Polish, Russian, Spanish, etc.	1

Learning objectives

- Independent implementation of a project
- Programming
- Planning
- Commissioning
- Analysis
- Correction

A universal system simulator has emerged from the connection of the software models and PROFI-CASSY. On one side, the PROFI-CASSY is connected to the PLC of the COM3LAB course Automation technology via the PROFIBUS and on the other side, it is connected to the PC via USB. There are process simulations for the various systems, which are simply installed on the PC as software. The actuators and the sensors of the simulated system are hence accessible for the real external control of the COM3LAB course via PROFI-CASSY.

Topics*

- Motor control
- Traffic light control
- Liquid level control
- Service lift
- Stamping machine

* you will receive further information on the course topics in the product section!

The COM3LAB course Bus and Automation technology teaches the basics of programmable logic controllers (PLC) and shows their interconnection including sensors and actuators using the PROFIBUS. With many examples, explanations, exercises and practical tasks, the basic principles and functions of the PLC and the PROFIBUS are clearly illustrated. The combination with external PROFIBUS components or an external system simulator enables the processes in the bus and automation technology to be illustrated and tracked as accurately as possible and without any great amount of effort.

M1.1.3
PROJECTS

M1.1.3.5
Power Electronics

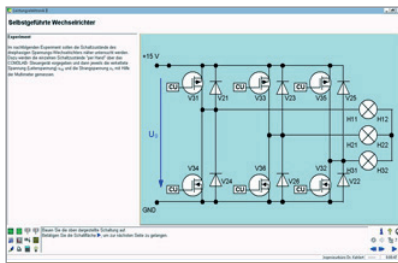

Power Electronics (M1.1.3.5)

Cat. No.	Description	M1.1.3.5
700 2101	COM3LAB course: Power electronics I	1
700 22	COM3LAB course: Power electronics II	1
700 020	COM3LAB Master Unit	1
700 022	Safety cable 2mm	1
700 00CBTDE	DVD: COM3LAB software, German	1
700 00CBTEN	DVD: COM3LAB software, English	1
735 297	Universal converter 3 x 230 V	1
735 290	Connecting lead universal converter	1
732 104	Squirrel cage motor 230/400/0.3	1
731 07	Shaft end guard 0.3	1
726 71	Single-phase supply unit	1
500 59	Safety bridging plugs, black, set of 10	1
500 851	Safety connecting leads, 32 A, set of 32	1
726 19	Panel frame SL85, single-level	1
	700 00CBTXX - The COM3LAB - Software is also available in French, Dutch, Polish, Russian, Spanish, etc.	1

Power electronics is an important area within electrical engineering. It combines the areas of power engineering, control and regulation technology and electronics. The advances in the production of semiconductor power components such as diodes, thyristors, triacs and power transistors have considerably facilitated their breakthrough. The task of the power electronics is switching, controlling and converting electrical energy with the help of electronic components.

In the project work the unloaded asynchronous machine (732 104) is supplied with three-phase current 3 x 230 V via the universal converter (735 297). The converter is parameterized via an interface integrated in the board, directly from the COM3LAB course.

Learning objectives

- Independent execution of the project
- Analysis
- Parameterization
- Correction

With the COM3LAB Power engineering course the operating behaviour of the machine is examined first and the identified parameters entered into the frequency converter of the COM3LAB. You can operate your 300 W set of machines with the power universal converter connected to the COM3LAB interface.

Topics*

- Semiconductor
- Circuits
- Key parameters
- Static converter

* you will receive further information on the course topics in the product section!

M1.1.3 PROJECTS

M1.1.3.6 Drive Technology

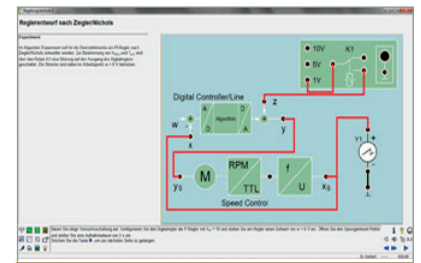

Drive Technology (M1.1.3.6)

Cat. No.	Description	M1.1.3.6
700 2501	COM3LAB course: Electrical machines I	1
700 8201	COM3LAB course: Control technology I	1
700 83	COM3LAB course: Control technology II	1
700 020	COM3LAB Master Unit	1
700 022	Safety cable 2mm	1
700 00CBTDE	DVD: COM3LAB software, German	1
700 00CBTEN	DVD: COM3LAB software, English	1
731 91	Shunt wound machine 0.3	1
731 09	Tacho generator 0.3	1
731 06	Coupling 0.3	1
731 07	Shaft end guard 0.3	1
731 08	Coupling guard 0.3	1
734 22	Actuator, 115...230 V/1 kW	1
734 19	Gain and offset adjust	1
726 86	Stabilised power supply ± 15 V/3 A	1
500 851	Safety connecting leads, 32 A, set of 32	1
500 852	Safety connecting leads, 32 A, yellow/green, set of 10	1
500 59	Safety bridging plugs, black, set of 10	1
726 19	Panel frame SL85, single-level	1
775 190EN	LIT: E2.2.2.0 DC Machines 0.3 (English)	1
	700 00CBTXX - The COM3LAB - Software is also available in French, Dutch, Polish, Russian, Spanish, etc.	1

The equipment includes the COM3LAB courses Electric machines I and Control technology I + II and a shunt wound machine. With these, important experiments can be carried out in the field of electric drives.

In the project work, the speed control of a commercial shunt wound machine was carried out with 300 W. For this reason it is necessary to configure the digital controller of the COM3LAB course Control technology II and to optimise it for the industrial motor.

Learning objectives

- Independent execution of a project
- Configuration of a controller
- Evaluation of the measuring results

With the COM3LAB course Electric machines I the operating performance of electrical machines will first be examined both on physical, mechanical level and by recording speed torque characteristics. Connection technologies of electrical machines, alteration of rotational direction and speed as well as the wiring of the terminal board are the subject of the experiments.

With the Control technology course the foundations of speed-controlled drives are examined. The key parameters of control systems are measured and the dimensions of closed control loops illustrated experimentally.

Topics*

- Function of electric machines
- Recording of characteristics
- Function of various controllers
- Speed control of a shunt wound machine

* you will receive further information on the course topics in the product section!

FOLLOW US!

VIDEOS ON YOUTUBE

Videos about new product features and experiments are posted regularly on the LD DIDACTIC YouTube Channel.



WWW.YOUTUBE.COM/USER/LDDIDACTIC



COM3LAB

M1.2 AUTOMOTIVE TECHNOLOGY

M1.2.1 FUNDAMENTALS

M1.2.1.1 Electrics

M1.2.1.2 Sensors

M1.2.1.3 Digital Technology

M1.2.2 SPECIALIZATIONS

M1.2.2.1 Bus Systems

M1.2.1
FUNDAMENTALS

M1.2.1.1
Electrics

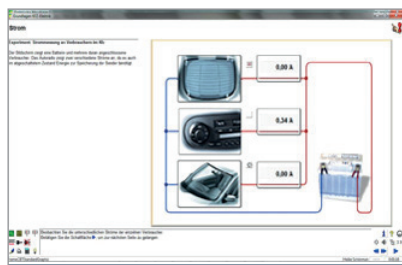

Electrics (M1.2.1.1)

Cat. No.	Description	M1.2.1.1
700 6101	COM3LAB Course: Automotive technology I	1
700 020	COM3LAB Master Unit	1
700 022	Safety cable 2mm	1
700 00CBTDE	DVD: COM3LAB software, German	
700 00CBTEN	DVD: COM3LAB software, English	1
	700 00CBTXX - The COM3LAB - Software is also available in French, Dutch, Polish, Russian, Spanish, etc.	

Nowadays cars without electronics are hard to imagine. These cars would be not suitable for everyday and everyone's use in modern traffic systems. While only a few devices in the car (windscreen wipers, starter etc.) used to operate electrically, the electrics today perform control functions (engine control, air conditioning, ABS etc.). This fact requires an extensive knowledge in the field of electrics.

The COM3LAB Electrics course has been developed with the automotive industry and therefore enables a solid electrical basic training.

Learning objectives

- Learning physical basic principles
- Calculating circuits
- Measuring

In the COM3LAB course Motor vehicle electrics the parameters of voltage, current and resistance are explained in a comprehensible way and additionally considered in the chapter „Calculating with parameters“ using graphic animations and videos. Measurements of real, motor vehicle-relevant components with analog and digital measuring instruments lead to the understanding of simple electrical circuits.

Topics

- Voltage, current, resistance
- Ohm's law
- Electrical power
- Electric circuits
- Series and parallel circuits
- Complex circuits
- General measuring instruments
- Analog/digital measuring instruments for measurements of components / vehicle electrical system

M1.2.1 FUNDAMENTALS

M1.2.1.2 Sensors

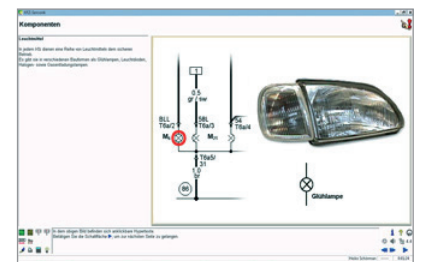
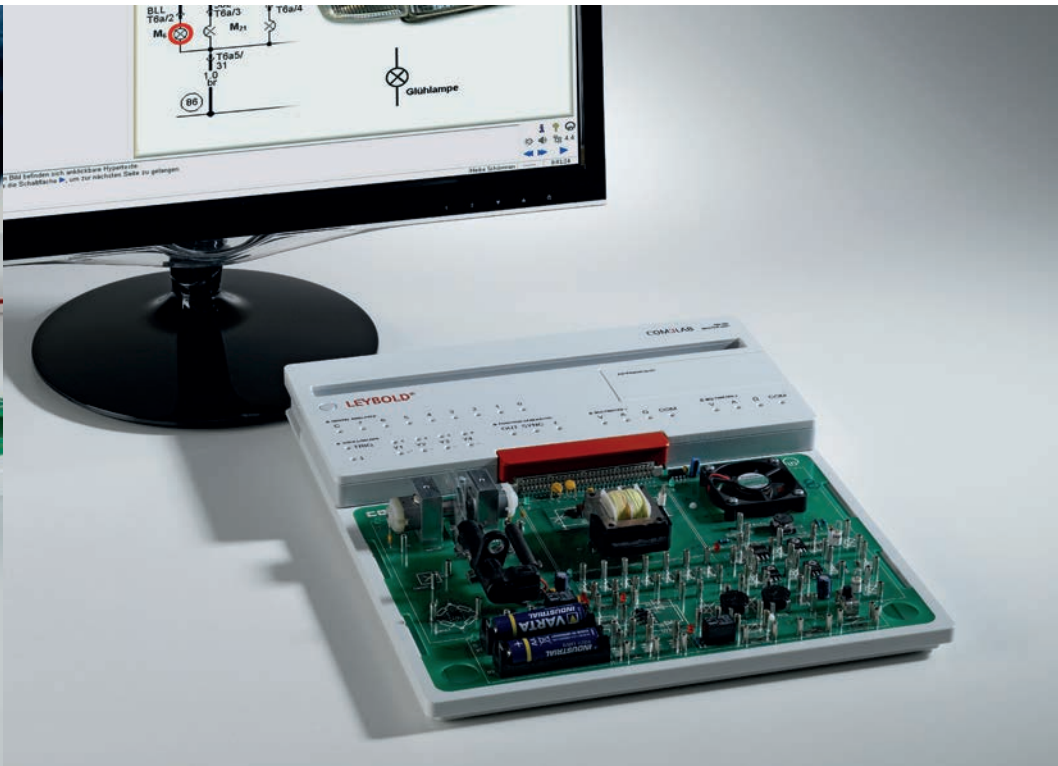

Cat. No.	Description	M1.2.1.2
700 6201	COM3LAB vehicle sensors	1
700 020	COM3LAB Master Unit	1
700 022	Safety cable 2mm	1
700 00CBTDE	DVD: COM3LAB software, German	
700 00CBTEN	DVD: COM3LAB software, English	1
	700 00CBTXX - The COM3LAB - Software is also available in French, Dutch, Polish, Russian, Spanish, etc.	

Nowadays many things run fully automatically in modern vehicles. The light goes on when it gets dark, the windscreen wiper adapts its wiping speed to the amount of rain. Up to 100 sensors are installed in the vehicle for this reason. They detect physical parameters like temperatures, speeds, angles, pressures etc. and transform these non-electric parameters into electric parameters.

The COM3LAB Motor vehicle sensor system therefore deals with the electric components and sensors in the vehicle.

Learning objectives

- Learning physical basic principles
- Getting to know the most important components and sensors

The course "Automotive Sensor Technology" explains the function of the electric components and sensors in a motor vehicle in detail. The course contents are completed by extensive instructions on practical troubleshooting. Comprehension questions and parallel voice output guarantee the greatest possible learning efficiency compared to traditional training methods.

Topics

- Lines
- Components
- Sensors
- Batteries and accumulators
- Electric fields
- Capacities
- Generators
- Motors
- Transistors in the motor vehicle

M1.2.1 FUNDAMENTALS

M1.2.1.3 Digital Technology

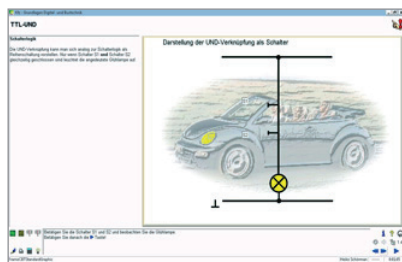

Digital Technology (M1.2.1.3)

Cat. No.	Description	M1.2.1.3
700 6401	COM3LAB Course: Vehicle fundamentals Digital and Bus Technology	1
700 6501	COM3LAB Course: Automotive digital technology II	1
700 020	COM3LAB Master Unit	1
700 022	Safety cable 2mm	1
700 00CBTDE	DVD: COM3LAB software, German	
700 00CBTEN	DVD: COM3LAB software, English	1
	700 00CBTXX - The COM3LAB - Software is also available in French, Dutch, Polish, Russian, Spanish, etc.	

Topics

- TTL-AND
- TTL-OR
- TTL-NOT
- TTL-XOR
- TTL-NAND
- Logic links
- Coding
- Multiplexer
- Fundamentals CAN Bus

In the COM3LAB course Vehicle-digital memory circuits flip-flop circuits are introduced. Animations and interactions make the foundations of modern bus systems clear. The topic areas are practical and adapted to the automotive technology in terms of application.

The COM3LAB courses Digital technology I + II form the basis for data exchange in the vehicle.

Learning objectives

- Structure, function and effect of the individual logic elements
- Learning important laws
- Using TTL components in application circuits

In the COM3LAB Digital technology for motor vehicle occupations course the foundations of the switching algebra are dealt with using logic links. Animations and interactions make the foundations of modern bus systems clear. The topic areas are practical and adapted to the automotive technology in terms of application.

Topics:

- Flip-flop
- RS flip-flop
- JK Flip-flop
- Shift register
- Counter
- Multivibrators
- Impulse diagram

M1.2.2 SPECIALIZATIONS

M1.2.2.1 Bus Systems

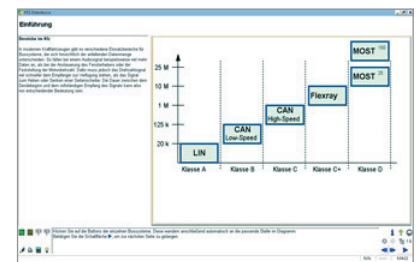
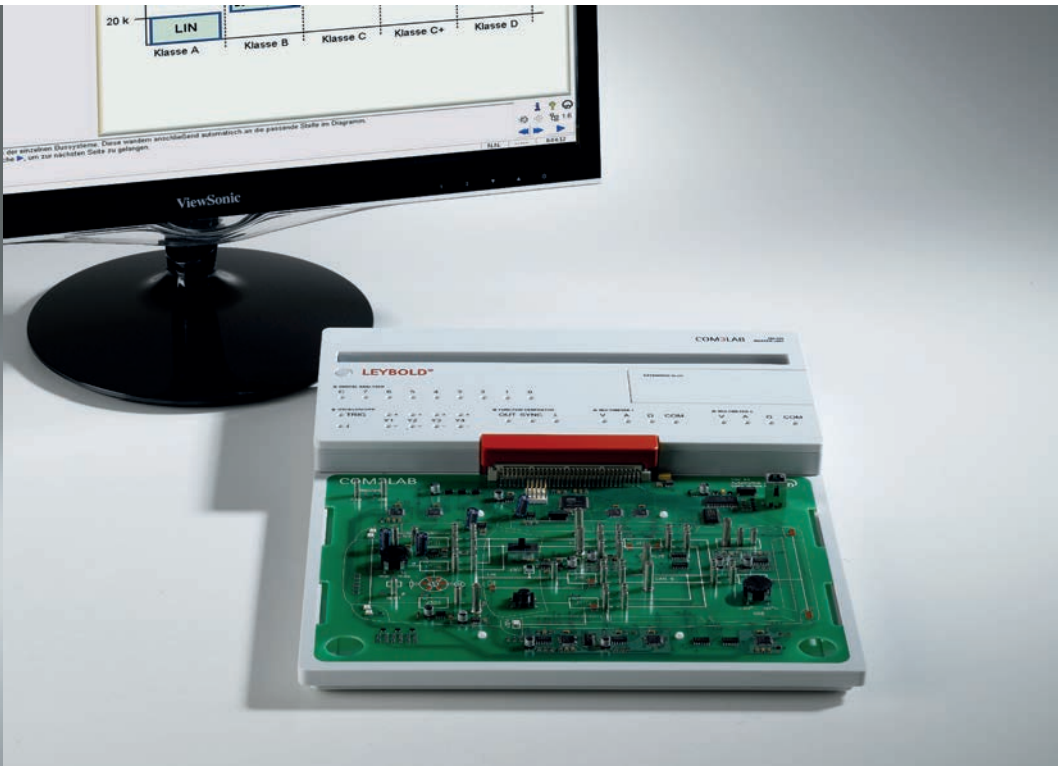

Bus Systems (M1.2.2.1)

Cat. No.	Description	M1.2.2.1
700 6301	COM3LAB Course: Automotive Data Buses	1
700 020	COM3LAB Master Unit	1
700 022	Safety cable 2mm	1
700 00CBTDE	DVD: COM3LAB software, German	
700 00CBTEN	DVD: COM3LAB software, English	1
	700 00CBTXX - The COM3LAB - Software is also available in French, Dutch, Polish, Russian, Spanish, etc.	

In order to meet ever greater requirements in the vehicle of driving safety, exhaust emission characteristics, fuel consumption and comfort, information is permanently exchanged between the control units and the terminal. In order to process the abundance of information in a timely manner, data buses are used. This requires extensive knowledge of function and use in the vehicle. The COM3LAB Vehicle databuses course takes these requirements into account.

Learning objectives

- Identification and diagnosis of data buses
- Fault analysis

In the COM3LAB Vehicle data buses course the interconnected electronic systems in the automotive technology are comprehensibly prepared and taught. Learning the various bus systems and their application areas are emphasized. Here, action-oriented tasks lead to a comprehensive understanding of the connections in the vehicle. Measuring technology as well as troubleshooting and fault correction complete the learning content.

Topics

- Digital technology: Foundations of digital technology
- Bus systems: CAN, LIN, SENT
- Measuring technology: signal sequence, logs, fault analysis
- Connection with external components: Communication and control of external systems (Training card, vehicles) via bus systems
- Other applications and system components





COM3LAB

M1.3 RENEWABLE ENERGY

M1.3.1 FUNDAMENTALS

M1.3.1.1 Photovoltaics

M1.3.1 FUNDAMENTALS

M1.3.1.1 Photovoltaics

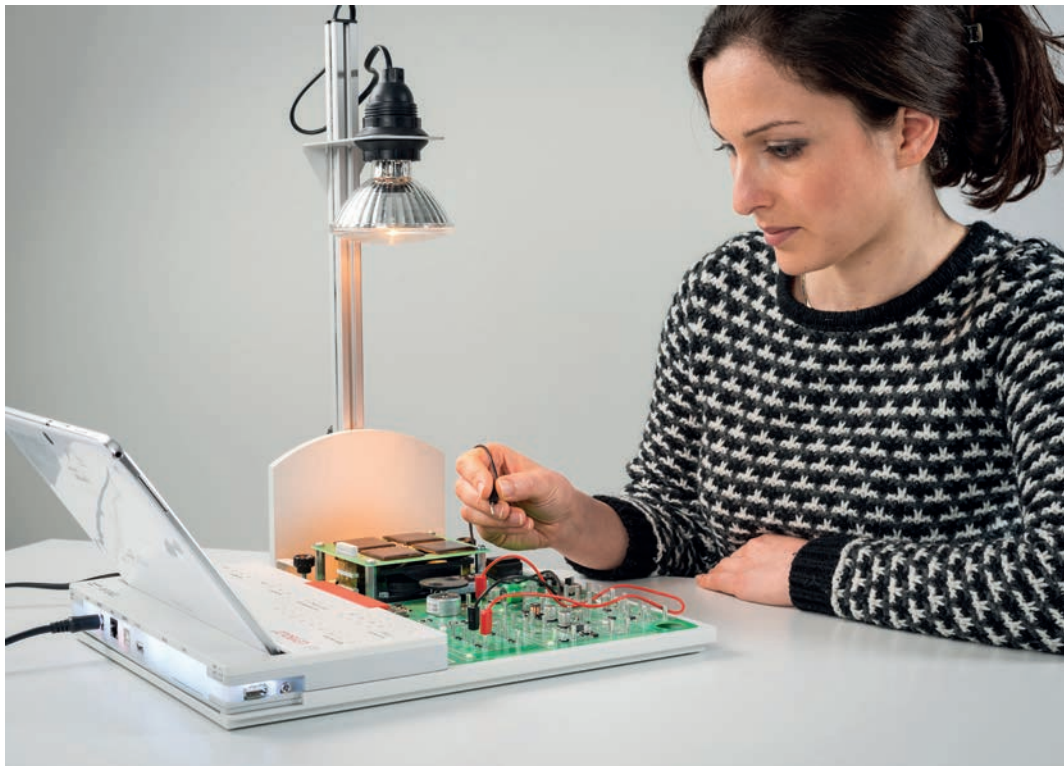
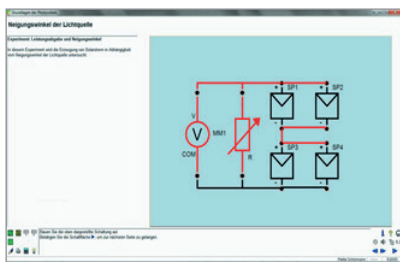

Photovoltaics (M1.3.1.1)

Cat. No.	Description	M1.3.1.1
700 5301	COM3LAB course: Photovoltaic	1
700 020	COM3LAB Master Unit	1
700 022	Safety cable 2mm	1
700 00CBTDE	DVD: COM3LAB software, German	
700 00CBTEN	DVD: COM3LAB software, English	1
	700 00CBTXX - The COM3LAB - Software is also available in French, Dutch, Polish, Russian, Spanish, etc.	

Photovoltaics (PV) is the direct conversion of sunlight into electrical energy through solar cells. Solar collectors today are found in industry and in the private sector, and will also play a significant role in the future.

Learning objectives

- Function and application of a solar collector

The COM3LAB Photovoltaics course is a foundation course on using solar cells. It deals with the structure and the function of solar cells. Using several experiments, the function of solar modules in different conditions is examined. With animations and several illustrations, this course gives a clear introduction to the world of photovoltaic systems.

Topics

- Solar cells (features, function, etc.)
- Solar module (features, function, etc.)
- Circuit types of solar modules
- Solar characteristics
- Influence of temperature
- Influence of shades
- Charging circuit
- Solar charge controller
- Photovoltaics system
- Applications

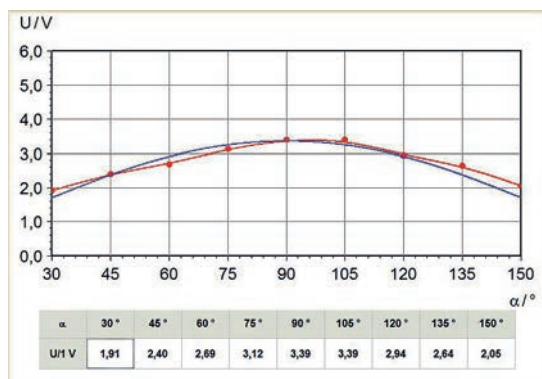

Inclination angle of the light source



COM3LAB

PRODUCT SECTION

IN NUMERICAL ORDER

On the following pages you will find all individual components in numerical order of the catalogue numbers.



Connecting lead, 19 A, 25 cm, black

For low-voltage circuits. Copper wires with plugs at both ends and fully insulated axial plug for adding additional leads. Black.

Technical Specifications:

- Plugs and sockets: 4 mm diam.
- Cross-section of conductor: 1 mm²
- Max. continuous current: 19 A
- Length: 25 cm

500 414	Connecting lead, 19 A, 25 cm, black
---------	-------------------------------------



Connecting lead 19 A, 100 cm, black

For low-voltage circuits. Copper wires with plugs at both ends and fully insulated axial plug for adding additional leads. Black.

Technical Specifications:

- Plugs and sockets: 4 mm diam.
- Cross-section of conductor: 1 mm²
- Max. continuous current: 19 A
- Length: 100 cm

500 444	Connecting lead 19 A, 100 cm, black
---------	-------------------------------------



Safety bridging plugs, black, set of 10

For use in low-voltage circuits.

Technical Specifications:

- Plugs: safety plugs, 4 mm diam.
- Pin spacing: 19 mm
- Current: 25 A

500 59	Safety bridging plugs, black, set of 10
--------	---

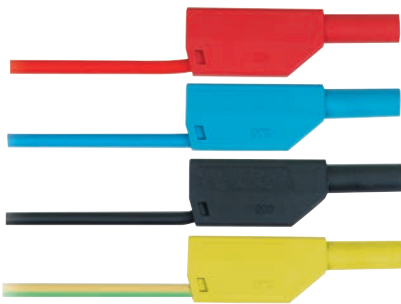

Safety connecting lead, 10 cm, black

For use in low-voltage circuits. Flexible, safety plug with axial safety socket at both ends. Black.

Technical Specifications:

- Conductor cross-section: 2.5 mm²
- Steady current: max. 32 A
- Length: 10 cm

500 604	Safety connecting lead, 10 cm, black
---------	--------------------------------------



Safety connecting lead, 25 cm, yellow/green

For use in low-voltage circuits. Flexible, safety plug with axial safety socket at both ends. Yellow-green.

Technical Specifications:

- Conductor cross-section: 2.5 mm²
- Steady current: max. 32 A
- Length: 25 cm

500 610	Safety connecting lead, 25 cm, yellow/green
---------	---

Safety connecting lead, 25 cm, red

For use in low-voltage circuits. Flexible, safety plug with axial safety socket at both ends. Red.

Technical Specifications:

- Conductor cross-section: 2.5 mm²
- Steady current: max. 32 A
- Length: 25 cm

500 611 Safety connecting lead, 25 cm, red



Safety connecting lead, 25 cm, blue

For use in low-voltage circuits. Flexible, safety plug with axial safety socket at both ends. Blue.

Technical Specifications:

- Conductor cross-section: 2.5 mm²
- Steady current: max. 32 A
- Length: 25 cm

500 612 Safety connecting lead, 25 cm, blue



Safety connecting lead, 25 cm, black

For use in low-voltage circuits. Flexible, safety plug with axial safety socket at both ends. Black.

Technical Specifications:

- Conductor cross-section: 2.5 mm²
- Steady current: max. 32 A
- Length: 25 cm

500 614 Safety connecting lead, 25 cm, black



Safety connecting lead, 50 cm, yellow/green

For use in low-voltage circuits. Flexible, safety plug with axial safety socket at both ends. Yellow-green.

Technical Specifications:

- Conductor cross-section: 2.5 mm²
- Steady current: max. 32 A
- Length: 50 cm

500 620 Safety connecting lead, 50 cm, yellow/green



Safety connecting lead, 50 cm, red

For use in low-voltage circuits. Flexible, safety plug with axial safety socket at both ends. Red.

Technical Specifications:

- Conductor cross-section: 2.5 mm²
- Steady current: max. 32 A
- Length: 50 cm

500 621 Safety connecting lead, 50 cm, red



Safety connecting lead, 50 cm, blue

For use in low-voltage circuits. Flexible, safety plug with axial safety socket at both ends. Blue.

Technical Specifications:

- Conductor cross-section: 2.5 mm²
- Steady current: max. 32 A
- Length: 50 cm

500 622 Safety connecting lead, 50 cm, blue





Safety connecting lead, 50 cm, black

For use in low-voltage circuits. Flexible, safety plug with axial safety socket at both ends. Black.

Technical Specifications:

- Conductor cross-section: 2.5 mm²
- Steady current: max. 32 A
- Length: 50 cm

500 624	Safety connecting lead, 50 cm, black
---------	--------------------------------------



Safety connecting lead, 100 cm, yellow/green

For use in low-voltage circuits. Flexible, safety plug with axial safety socket at both ends. Yellow-green.

Technical Specifications:

- Conductor cross-section: 2.5 mm²
- Steady current: max. 32 A
- Length: 100 cm

500 640	Safety connecting lead, 100 cm, yellow/green
---------	--



Safety connecting lead, 100 cm, red

For use in low-voltage circuits. Flexible, safety plug with axial safety socket at both ends. Red.

Technical Specifications:

- Conductor cross-section: 2.5 mm²
- Steady current: max. 32 A
- Length: 100 cm

500 641	Safety connecting lead, 100 cm, red
---------	-------------------------------------



Safety connecting lead, 100 cm, blue

For use in low-voltage circuits. Flexible, safety plug with axial safety socket at both ends. Blue.

Technical Specifications:

- Conductor cross-section: 2.5 mm²
- Steady current: max. 32 A max.
- Length: 100 cm

500 642	Safety connecting lead, 100 cm, blue
---------	--------------------------------------



Safety connecting lead, 100 cm, black

For use in low-voltage circuits. Flexible, safety plug with axial safety socket at both ends. Black.

Technical Specifications:

- Conductor cross-section: 2.5 mm²
- Steady current: max. 32 A
- Length: 100 cm

500 644	Safety connecting lead, 100 cm, black
---------	---------------------------------------

Safety connecting leads, 32 A, set of 32

For use in low-voltage circuits. Flexible PVC strand, safety plugs with axial safety socket at both ends.

Technical Specifications:

- Plugs and sockets: 4 mm diameter (nickel plated)
- Conductor cross-section: 2.5 mm²
- Steady current: max. 32 A
- Contact resistance: 1.8 mΩ

Scope Of Delivery:

Count	Cat.No	Name
4	500 604	Safety connecting lead, 10 cm, black
2	500 611	Safety connecting lead, 25 cm, red
2	500 612	Safety connecting lead, 25 cm, blue
6	500 614	Safety connecting lead, 25 cm, black
2	500 621	Safety connecting lead, 50 cm, red
2	500 622	Safety connecting lead, 50 cm, blue
6	500 624	Safety connecting lead, 50 cm, black
2	500 641	Safety connecting lead, 100 cm, red
2	500 642	Safety connecting lead, 100 cm, blue
4	500 644	Safety connecting lead, 100 cm, black

500 851	Safety connecting leads, 32 A, set of 32
---------	--

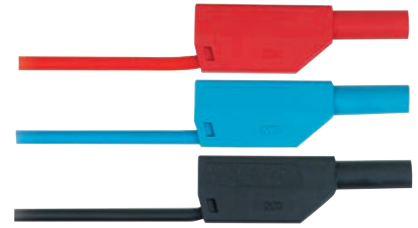

Safety connecting leads, 32 A, yellow/green, set of 10

For use in low-voltage circuits. Flexible, safety plugs with axial safety sockets at both ends.

Technical Specifications:

- Conductor cross-section: 2.5 mm²
- Steady current: max. 32 A

Scope Of Delivery:

Count	Cat.No	Name
2	500 610	Safety connecting lead, 25 cm, yellow/green
4	500 620	Safety connecting lead, 50 cm, yellow/green
4	500 640	Safety connecting lead, 100 cm, yellow/green

500 852	Safety connecting leads, 32 A, yellow/green, set of 10
---------	--



Connecting lead, 19 A, 25 cm, black, pair

For extra-low voltage circuits. Copper wire, equipped at both ends with a plug and fully insulated axial socket for connecting further cables.

Technical Specifications:

- Plugs and sockets: 4 mm diameter
- Conductor cross-section: 1.0 mm²
- Continuous current: 19 A max.
- Length: 25 cm

Scope Of Delivery:

Count	Cat.No	Name
2	500 414	Connecting lead, 19 A, 25 cm, black

501 441	Connecting lead, 19 A, 25 cm, black, pair
---------	---





Connecting leads, 19 A, 100 cm, black, pair

For use in extra-low voltage circuits. Copper wires, plug with fully insulated axial socket for connecting additional leads.

Technical Specifications:

- Plugs and sockets: 4 mm diam.
- Conductor cross-section: 1 mm²
- Continuous current: 19 A max.
- Length: 100 cm

Scope Of Delivery:

Count	Cat.No	Name
2	500 444	Connecting lead 19 A, 100 cm, black

501 461	Connecting leads, 19 A, 100 cm, black, pair
---------	---



Set of 10 bridging plugs, black

Technical Specifications:

- 4-mm bridging plugs
- 19-mm spacing
- 32 A current

501 511	Set of 10 bridging plugs, black
---------	---------------------------------



Bridging plugs with tap, black, set of 10

4-mm bridging plugs with 19 mm spacing with 4-mm tap. Max. current 32 A.

501 512	Bridging plugs with tap, black, set of 10
---------	---

Profi-CASSY Starter 2

The Profi-CASSY starter package is intended for unlimited experimentation. It consists of a Profi-CASSY module with interface (524 016), plus CASSY Lab 2 software (524 220).

Technical Specifications:

- **16 digital inputs I0 to I15**
(5 V or 24 V logic)
- Sampling rate: max. 100 values/s
- **16 digital outputs, Q0 to Q15**
(5 V or 24 V logic)
Output current: 10 mA with internal 5 V power supply, 500 mA via external power supply of up to 30 V
- Total current: 2 A
The digital inputs/outputs are each equipped with 10-pin plugs for direct connection to automation equipment. Also 8 inputs and 8 outputs are additionally equipped with 2-mm sockets and status LEDs
- **2 analog voltage inputs, A and B**
4-mm safety sockets
Resolution: 12 bits
Amplitude: ± 10 V
Measuring error: $\pm 1\%$ plus 0.5% from the end value of range
Input resistance: 1 M Ω
Sampling rate: max. 10,000 values/s
- **2 analog outputs, X and Y**
4-mm safety sockets
Amplitude: ± 10 V
Output current: max. 100 mA per Output
Resolution: 12 bits, measuring error: $\pm 1\%$ plus 0.5% from the end value of range
- Sampling rate: 10,000 values/s
- **1 PROFIBUS connection**
9-pin DSUB socket
Passive user (slave) on fieldbus
PROFIBUS-DP
Address adjustable via software with 16 digital inputs/outputs
Transmission rate up to max. 3 Mbits/s



- **USB port**
for connection to PC
- **1 CASSY-Bus module**
or connection to Sensor- or Power-CASSY modules
- **Dimensions (WxHxD):** 115 mm x 295 mm x 45 mm
- **Weight:** 1 kg

Scope Of Delivery:

- 1 Profi-CASSY module
- CASSY Lab software with enable code for Windows XP/Vista/7/8 (32+64 bit) and extensive help
- 1 Installation guide
- 1 USB cable
- 1 power adapter 230/12 V/1.6 A
- 1 GSD file for simple parameter settings

524 016S2	Profi-CASSY Starter 2
-----------	-----------------------

Plug-in power supply, 12 V AC

Universal plug-in power supply, e.g. for CASSY, counter S, counter P, electrometer amplifier etc.

Technical Specifications:

- Primary: 230 V AC, 50/60 Hz
- Secondary: 12 V AC, 20 VA

Connection: coaxial power connector

562 791	Plug-in power supply, 12 V AC
---------	-------------------------------



LIT: Control of Technical Lines I

Detailed representation of experiments to Control of technical Lines (part I), included results for the teacher and Measurements with CASSY Lab 2. DIN A4, in german.

Topics:

- Temperature Control
- Liquid: Flow – Measurement & Control
- Liquid Level: Measurement & Control
- Gas flow control

564 24EN	LIT: Control of Technical Lines I
----------	-----------------------------------

LIT: Control of technical control loops II, German

Comprehensive instructions for experiments on the closed-loop control of technical control loops (part II), including experiment results for teachers and measurements using CASSY Lab 2. DIN A4 format in German.

Topics:

- Closed-loop control of speed and voltage (using 10 W machine set)

564 25EN	LIT: Control of technical control loops II, German
----------	--

LIT: Fundamentals of Automatic Control Technology II, Vol. 2

TECHNOLOGY II, Vol.2.

Automatic control of physical variables in the frequency range. DIN A4, in German.

568 222	LIT: Fundamentals of Automatic Control Technology II, Vol. 2
---------	--

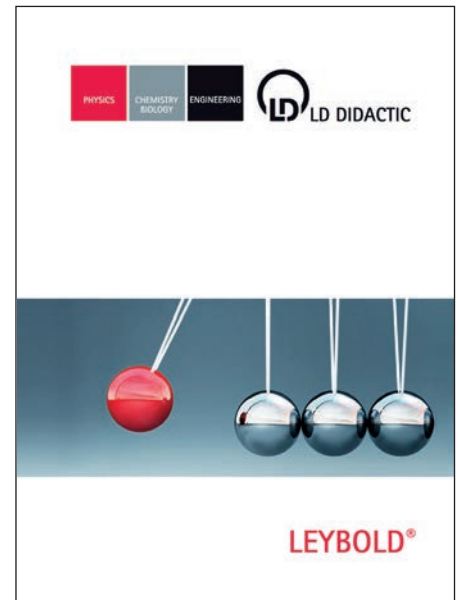



LIT: DC Machines (in German) T 10.2.1

93 Illustrations and Diagrams, 130 pages, DIN A4. Language: German.

Topics:

- Experiments with the Shunt Wound Machine
- Experiments with the Series Wound Machine
- Experiments with the Compound Wound Machine
- Experiments with the DC Multifunction Machine
- Experiments with the Universal Motor
- Refresher Questions

569 2101L | LIT: DC Machines (in German) T 10.2.1

Storage tray S24-FN

For storage of equipment, especially equipment used in students' experiments. Study construction, made of 4-mm-thick, drawn material with grooves for partitions, can be sub-divided into ten sections.

Technical Specifications:

- External dimensions: 240 mm x 460 mm x 80 mm

648 07 | Storage tray S24-FN

Fits partition 648 08

Partition ZW 24

For dividing the storage tray (648 07)

Technical Specifications:

- Width: 240 mm

648 08 | Partition ZW 24

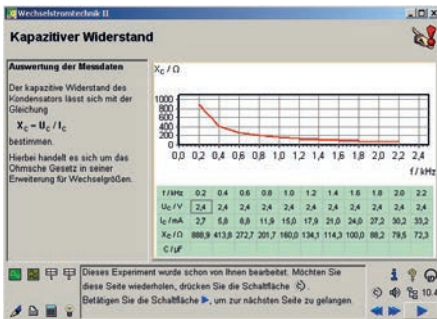

COM3LAB software

CD containing the software for all available COM3LAB courses in German. For each COM3LAB multimedia course there is an electronic, interactive instruction manual. The contents of the manual are dependent on the topic and are tailored to the hardware. The operation and function of the manuals are identical for all courses. The 32-bit user interface, into which the interactive manual, the virtual lab and the tools are integrated, also remains the same for all courses. Structure of multimedia course software:

- Electronic manual
- Virtual lab (oscilloscope, multimeters, function generator etc.)
- Tools (printers, calculators, word processing, copy function for measurement results)
- Help
- Glossary
- Table of contents

Cat.No	Description
700 00CBTDE	DVD: COM3LAB software, German
700 00CBTEN	DVD: COM3LAB software, English
700 00CBTFR	CD: COM3LAB software, French
700 00CBTIT	CD: COM3LAB software, Italian
700 00CBTNL	CD: COM3LAB software, Dutch
700 00CBTPT	CD: COM3LAB software, Portuguese
700 00CBTRU	CD: COM3LAB software, Russian
700 00CBTSP	CD: COM3LAB software, Spanish

COM3LAB Master Unit

The COM3LAB Master Unit is the multifunctional, compact measuring interface. It is used for the operation and the power supply to the COM3LAB multimedia experiment boards and as an independent measuring laboratory. The Master Unit is connected to the PC via USB Port, WiFi or Ethernet for the recording of measurements and for remote control of its built-in functions. The Master Unit can be quickly assembled and dismantled and easily commissioned. The clear and structured design of the Master Unit makes it easy and self-explanatory to operate.



Characteristics:

- 4-channel oscilloscope
- 2 digital multimeters
- Digital analyser
- Function generator
- Frequency counter
- Integrated USB interface for external measuring instruments
- USB charging socket for tablets
- Light strip and LEDs for status display
- two separate audio outputs so that two schoolchildren can work with the Master Unit at the same time (suitable for inclusion)
- Interfaces:
 - Network interface 100 Mbits RJ45
 - WiFi
 - USB
- Security lock for fastening the experimentation boards
- Anti-theft protection (Port for Kensington lock)

Software support

- Windows 8 / 8.1 32/64 Bit
- Windows 7
- Windows Vista

Integrated measuring instruments and functions:

- Two digital multimeters:
Voltage: AC / DC / AD + DC 2/20 V
Current: AC/DC 0,2/2 A
Resistance: 2/20/200 kΩ, 2 MΩ
Autoranging for all measurement ranges
- Digital Function generator:
digitally generated signal types
Sinusoidal, square-wave, triangular, DC
0.5 Hz...100 kHz
Max. ±10 V, max. 250 mA
- Digital 4-channel oscilloscope:
4 differential inputs
Sampling rate: 2 MSamples per channel
Resolution: 12 Bit per channel
Memory depth: 2 K Samples per channel
- Digital analyser:
9 digital inputs, TTL-compatible
Sampling frequency: 200 Hz to 2 MHz
Triggering on any combination of the input statuses
Memory depth 2048 words with 9 Bits

The real measuring instruments can be read out and operated via the software

Scope of delivery

- USB cable
- Ethernet cable
- Power supply DC 15V 6A 90W
- Course framework (700 021 - for upgrading existing experimentation boards for operation with the Master Unit 700 020)

Also required

- 700 022 - 1 set of safety cables (2 mm)
or
- 689 0600 - 1 set of standard cables (2 mm)
700 021 - 1 course framework (700 021 - for upgrading existing experimentation boards for operation with the Master Unit 700 020)
- 700 024 - 10 course frameworks (700 021 -for upgrading existing experimentation boards for operation with the Master Unit 700 020)

700 020	COM3LAB Master Unit
---------	---------------------



COM3LAB 1 upgrade carrier standard

The COM3LAB upgrade carrier is used to insert COM3LAB experiment boards, so that they can work with the COM3LAB Master Unit 700 020.

With the new upgrade carrier, the circuit boards are better protected, easier to store and transport.

The packaging of the upgrade carrier is designed as a storage box for board and frame.

700 021	COM3LAB 1 upgrade carrier standard
---------	------------------------------------

Safety cable 2mm

Set of 2mm safety cables for COM3LAB Courses and the new Master Unit (700 020)

Scope Of Delivery:

2 x 150mm red
2 x 150mm blue
6 x 150mm black
2 x 300mm red
2 x 300mm blue
2 x 300mm black

700 022	Safety cable 2mm
---------	------------------

Power supply DC 15V 6A 90W

Power Supply (Desktop Version) for COM3LAB Master Unit 700 020

Technical Specifications:

Input Voltage range: 90 VAC to 264 VAC, 127 VDC to 370 VDC

No of Outputs: 1

Output Power: 90 W

Output Voltage: 15 V

Output Current: 6 A

DC-Plug: 2.5 mm Barrel Plug

700 023	Power supply DC 15V 6A 90W
---------	----------------------------



COM3LAB 8 upgrade carriers standard

Set of eight upgrade carriers in order to feature old COM3LAB work boards with the new Master Unit 700 020

700 024	COM3LAB 8 upgrade carriers standard
---------	-------------------------------------

COM3LAB course: DC technology I

Course on the fundamentals of direct current technology, consisting of a test board with 13 different circuits. This course introduces the basic concepts and laws of electrical engineering are explained and practically developed.

Topics:

- Circuits with switches
- Switches in series
- Switches in parallel
- Change-over switches
- Polarity reversing circuit
- Relays
- Conductivity
- Ohm's law
- Colour codes and IEC series
- Series-connected resistors
- Kirchhoff's law
- Voltage dividers
- Voltage dividers under load
- Wheatstone bridge

Virtual laboratory:

- Oscilloscope
- Function generator
- Multimeter (2x)
- Digital analyser

Additional functions:

- Word processing
- Printer
- Pocket calculator
- Free experimentation
- Glossary

The test board is located in a stable course frame. The Master Unit is pushed onto the course frame and connected to the board. The security lock ensures safe communication.

The experiment board is powered by the Master Unit.

The wiring of the experiments is carried out using a 2 mm cable.

Course content, experiment instructions and tasks are taught through a course-specific software.



700 1101	COM3LAB course: DC technology I
----------	---------------------------------

Additionally required:

Count	Cat.No	Name
1	700 00CBTEN	DVD: COM3LAB software, English
1	700 020	COM3LAB Master Unit
1	700 022	Safety cable 2mm
1		PC with Windows XP/Vista/7/8



COM3LAB course: DC technology II

Course on the fundamentals of direct current technology, consisting of a test board with 11 different circuits. In this course characteristics can be recorded and the basic types of electrical circuit can be mastered.

Topics:

- Incandescent lamp characteristic
- VDR characteristic
- Diode characteristic
- LDR characteristic
- NTC characteristic
- PTC characteristic
- Capacitors
- Capacitors connected in parallel
- Capacitors connected in series
- RC circuits
- Inductance
- Moving coil instrument
- Batteries
- Two batteries connected in parallel
- Two batteries connected in series

Virtual laboratory:

- Oscilloscope
- Function generator
- Multimeter (2x)
- Digital analyser

Additional functions:

- Word processing
- Printer
- Pocket calculator
- Free experimentation
- Glossary

The test board is located in a stable course frame. The Master Unit is pushed onto the course frame and connected to the board. The security lock ensures safe communication.

The experiment board is powered by the Master Unit.

The wiring of the experiments is carried out using 2 mm cable.

Course content, experiment instructions and tasks are taught through a course-specific software.

700 1201	COM3LAB course: DC technology II
----------	----------------------------------

Additionally required:

Count	Cat.No	Name
1	700 00CBTEN	DVD: COM3LAB software, English
1	700 020	COM3LAB Master Unit
1	700 022	Safety cable 2mm
1		PC with Windows XP/Vista/7/8

COM3LAB course: AC technology I

Course on the fundamentals of alternating current technology, consisting of a test board with 11 different circuits. This course covers the production of AC voltage, transformers and rectifier circuits.

Topics:

- Step voltage
- Continuous AC voltage
- Electronic generation of AC voltage
- Function generators and oscilloscopes
- Induction
- Principle of transformers
- Short-circuited transformers
- Transformers under load
- Transformer losses
- Diodes used as current valves
- M1 rectifiers
- M2 rectifiers
- B2 rectifiers
- Symmetrical output voltage

Virtual lab:

- Oscilloscope
- Function generator
- Multimeter (2x)
- Digital analyser

Additional functions:

- Word processing
- Printer
- Pocket calculator
- Free experimentation
- Glossary

The test board is located in a stable course frame. The Master Unit is pushed onto the course frame and connected to the board. The security lock ensures safe communication.

The experiment board is powered by the Master Unit.

The wiring of the experiments carried out over 2 mm cable.

Course content, experiment instructions and tasks are taught through a course-specific software.



700 1301	COM3LAB course: AC technology I
----------	---------------------------------

Additionally required:

Count	Cat.No	Name
1	700 00CBTEN	DVD: COM3LAB software, English
1	700 020	COM3LAB Master Unit
1	700 022	Safety cable 2mm
1		PC with Windows XP/Vista/7/8

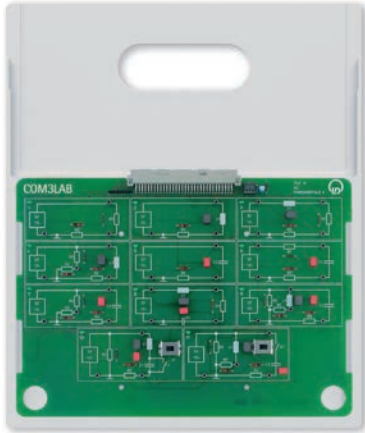

COM3LAB course: AC technology II

Course on the fundamentals of alternating current technology, consisting of a test board with 11 different circuits. This course covers the behaviour of resistance, coil and capacitor in an AC circuit.

Topics:

- Generating alternating voltages
- Key parameters of AC technology
- Ohmic resistance in an AC circuit
- Coils in an AC circuit
- Inductive reactance
- Series RL circuits
- Parallel RL circuits
- Capacitors in an AC circuit
- Capacitive reactance
- Series RC circuits
- Parallel RC circuits
- Series RLC circuits
- Parallel RLC circuits
- Series compensation
- Parallel compensation
- Voltage resonance
- Current resonance

Virtual laboratory:

- Oscilloscope
- Function generator
- Multimeter (2x)
- Digital analyser

Additional functions:

- Word processing
- Printer
- Pocket calculator
- Free experimentation
- Glossary

The experiment board is located in a stable course frame. The Master Unit is pushed onto the course frame and connected to the board. The security lock ensures safe communication.

The experiment board is powered by the Master Unit.

The wiring of the experiments carried out over 2 mm cable.

Course content, experiment instructions and tasks are taught through a course-specific software.

700 1401	COM3LAB course: AC technology II
----------	----------------------------------

Additionally required:

Count	Cat.No	Name
1	700 00CBTEN	DVD: COM3LAB software, German
1	700 020	COM3LAB Master Unit
1	700 022	Safety cable 2mm
1		PC with Windows XP/Vista/7/8

COM3LAB Course: Electronic components I

Course on the electronic components, consisting of a test board with 12 various circuits. This course provides the behaviour of diodes and transistors.

Topics:

- Diode characteristics
- Characteristic of a Z diode
- Characteristic of an LED
- Diode branches in a transistor
- Input characteristic of the transistor
- Output characteristics of the transistor
- Control characteristic of the transistor
- Power dissipation of a transistor
- Characteristic of a phototransistor
- Darlington circuit
- Operating point of a transistor
- Transistor in a common emitter circuit
- Transistor in a common collector circuit
- Transistor in a common base circuit
- Transistors in timer circuits

Virtual laboratory:

- Oscilloscope
- Function generator
- Multimeter (2x)
- Digital analyser

Additional functions:

- Word processing
- Printer
- Pocket calculator
- Free experimentation
- Glossary

The experiment board is located in a stable course frame. The Master Unit is pushed onto the course frame and connected to the board. The security lock ensures safe communication.

The experiment board is powered by the Master Unit.

The wiring of the experiments carried out over 2 mm cable.

Course content, experiment instructions and tasks are taught through a course-specific software.



700 1501	COM3LAB Course: Electronic components I
----------	---

Additionally required:

Count	Cat.No	Name
1	700 00CBTEN	DVD: COM3LAB software, English
1	700 020	COM3LAB Master Unit
1	700 022	Safety cable 2mm
1		PC with Windows XP/Vista/7/8



COM3LAB Course: Electronic components II

Course on the electronic components, consisting of a test board with 12 different circuits. This course explains the behaviour of FETs, MOSFETs and IGBTs.

Topics:

- Design of the FET
- Transfer characteristic of the JFET
- Output characteristic family of a JFET
- JFET as a switch
- Characteristics of the MOSFET
- The MOSFET as a switch
- Characteristics of the IGBT
- The IGBT as a switch
- Characteristic of the DIAC
- Characteristic of the thyristor
- Thyristor in the DC circuit
- Phase angle control with a thyristor
- Characteristic of the TRIAC
- Phase angle control with a TRIAC

Virtual lab:

- Oscilloscope
- Function generator
- 2 multimeters
- Digital analyser

Additional functions:

- Word processing
- Printer
- Pocket calculator
- Free experimentation
- Glossary

The experiment board is located in a stable course frame. The Master Unit is pushed onto the course frame and connected to the board. The security lock ensures safe communication.

The experiment board is powered by the Master Unit.

The wiring of the experiments carried out over 2 mm cable.

Course content, experiment instructions and tasks are taught through a course-specific software.

700 1601	COM3LAB Course: Electronic components II
----------	--

Additionally required:

Count	Cat.No	Name
1	700 00CBTEN	DVD: COM3LAB software, English
1	700 020	COM3LAB Master Unit
1	700 022	Safety cable 2mm
1		PC with Windows XP/Vista/7/8

COM3LAB course: Digital technology I

Course on the basics of digital technology (circuits), consisting of a test board with various components and logic gates. The course examines the principles and laws in digital technology.

Topics:

- TTL AND gates
- TTL OR gates
- TTL NOT gates (inverters)
- TTL XOR gates
- Boolean operations
- De Morgan's law
- TTL NAND gates
- Associative law
- Distributive law
- Karnaugh maps
- Coding
- Seven-segment displays
- Half-adders
- Full-adders
- Multiplexers/demultiplexers
- Fault simulation

Virtual laboratory:

- Oscilloscope
- Function generator
- Multimeter (2x)
- Digital analyser

Additional functions:

- Word processing
- Printer
- Pocket calculator
- Free experimentation
- Glossary

The experiment board is located in a stable course frame. The Master Unit is pushed onto the course frame and connected to the board. The security lock ensures safe communication.

The experiment board is powered by the Master Unit.

The wiring of the experiments carried out over 2 mm cable.

Course content, experiment instructions and tasks are taught through a course-specific software.

Technical Specifications:

- 4 x AND, 3 x OR, 2 x XOR, 2 x NOR, 3 x NAND
- Full adder
- 7 Segment display
- Multiplexers, Demultiplexers
- 4 command switches
- 2 sensors, 2 LEDs

Scope Of Delivery:

- Set of cables consisting of 5 connecting leads 30 cm equipped with 2-mm plugs.

700 1701	COM3LAB course: Digital technology I
----------	--------------------------------------

Additionally required:

Count	Cat.No	Name
1	700 00CBTEN	DVD: COM3LAB software, English
1	700 020	COM3LAB Master Unit
1	700 022	Safety cable 2mm
1		PC with Windows XP/Vista/7/8

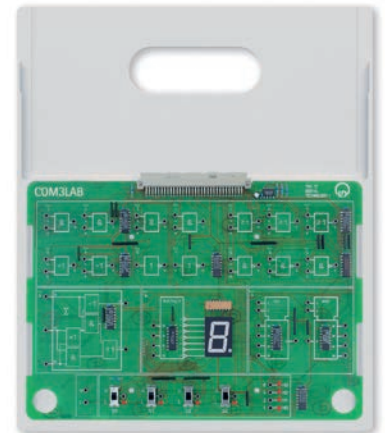

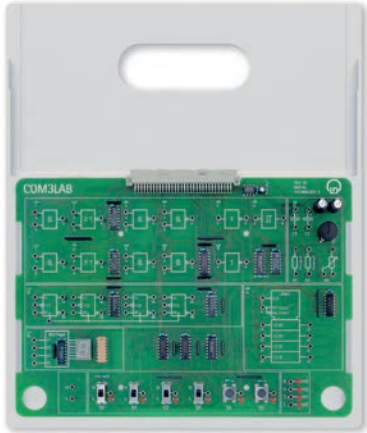

COM3LAB course: Digital technology II

Course on the basics of digital technology (switching networks), consisting of a test board with various circuits. The course deals with the operation and use of flip-flops.

Topics:

- Flip-flops
- RS flip-flops
- RS flip-flops with clock input
- Monostable and astable multivibrators
- Schmitt triggers
- D flip-flops
- JK flip-flops
- JK master-slave flip-flops
- Frequency dividers
- Counters
- Shift registers
- Parallel-serial converters

Virtual laboratory:

- Oscilloscope
- Function generator
- Multimeter(2x)
- Digital analyser

Additional functions:

- Word processing
- Printer
- Pocket calculator
- Free experimentation
- Glossary

The experiment board is located in a stable course frame. The Master Unit is pushed onto the course frame and connected to the board. The security lock ensures safe communication.

The experiment board is powered by the Master Unit.

The wiring of the experiments carried out over 2 mm cable.

Course content, experiment instructions and tasks are taught through a course-specific software.

Technical Specifications:

- 2 x AND, 2 x NOR, 4 x NAND
- 2 Inverter
- 1 Schmitt trigger
- 1 7-segment display
- 4 JK flip-flop
- 1 Universal shift register
- 4 command switches,
- 2 sensors, 4 LEDs

700 1801	COM3LAB course: Digital technology II
----------	---------------------------------------

Additionally required:

Count	Cat.No	Name
1	700 00CBTEN	DVD: COM3LAB software, English
1	700 020	COM3LAB Master Unit
1	700 022	Safety cable 2mm
1		PC with Windows XP/Vista/7/8

COM3LAB course: Power electronics I

Course on phase-commutated and self-commutated converter circuits, consisting of an experiment board with various circuits for mounting into the Master Unit and a multimedia CD with interactive training software.

Topics:

Introduction

- Semiconductors in power electronics
- Wiring and triggering
- Switching processes and commutation
- Uncontrolled rectifier circuits
- Parameters for periodic signals Controlled line-commutated static converters
- M1C circuit
- M3C-circuit
- B2C circuit
- B6C semi-controlled rectifiers

Virtual lab:

- Oscilloscope
- Function generator
- Multimeter (2x);
- Digital analyser
- Characteristic curve plotter
- Converter analyser
- Converter control unit

Additional functions:

- Word processing
- Printer
- Pocket calculator
- Free experimentation
- Glossary

The experiment board is located in a stable course frame. The Master Unit is pushed onto the course frame and connected to the board. The security lock ensures safe communication.

The experiment board is powered by the Master Unit.

The wiring of the experiments carried out over 2 mm cable.

Course content, experiment instructions and tasks are taught through a course-specific software.

Technical Specifications:

- 1 three-phase network generator in 50 and 60 Hz
- Self-commutated and line-commutated static converter (E1 to B6 circuit) with TSE protection
- H6-MOSFET frequency converter from 1 to 120 Hz
- Three independent amperemeters
- Three incandescent lamps as ohmic load
- Inductive and capacitive loads
- 4-channel multiplexer

Scope Of Delivery:

- Set of cables consisting of 40 cm and 5 cm long connecting leads with 2-mm plugs

700 2101	COM3LAB course: Power electronics I
----------	-------------------------------------

Additionally required:

Count	Cat.No	Name
1	700 00CBTEN	DVD: COM3LAB software, English
1	700 020	COM3LAB Master Unit
1	700 022	Safety cable 2mm
1		PC with Windows XP/Vista/7/8



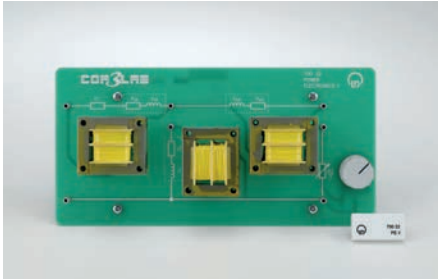

COM3LAB course: Power electronics II

Supplementary course on power inverters, DC choppers, converters and drive technology, consisting of a dongle for the PE I experiment board and a circuit board with the equivalent circuit of a three-phase induction machine including a rotating field indicator.

Topics:

- Self-commutated converters (power inverters)
- Semiconductor switches and controllers (bidirectional static converters)
- Switches and controller for DC
- Converters
- Static converters in automatic control technology
- Static converters in drive technology

Virtual lab:

- Oscilloscope
- Function generator
- Multimeters (2x)
- Digital analyser
- Characteristic curve plotter
- Converter analyser
- Converter control unit

Additional functions:

- Word processing
- Printer
- Pocket calculator
- Free experimentation
- Glossary

The 700 22 dongle is inserted on the experiment board 700 21. This will be powered by the Master Unit. The wiring of the experiments is carried out using 2 mm cable. Course content, experiment instructions and tasks are taught through a course-specific software.

Additionally required:

- 700 21 COM3LAB course: Power electronics I

Scope Of Delivery:

- Dongle
- Experiment board: replacement switch Asynchronous machine

700 22	COM3LAB course: Power electronics II
--------	--------------------------------------

Additionally required:

Count	Cat.No	Name
1	700 00CBTEN	DVD: COM3LAB software, English
1	700 2101	COM3LAB course: Power electronics I

COM3LAB course: Three-phase technology

This COM3LAB course investigates the behaviour of three-phase systems. Practical exercises show the generation of the rotary fields or the function of the transformer. Furthermore, passive components in different circuits are discussed. Coils, capacitors and resistors are analysed and evaluated in different circuits. An 8-channel oscilloscope enables the simultaneous measurement of all voltages and currents in the three-phase system.

Topics:

- Characteristics of a three-phase system
- Representation of line diagrams and phase relationships
- Star- and delta circuits with different loads
- Measurement of phase and line voltage/current
- Ohmic load
- Symmetrical and unsymmetrical charges
- Measurement of power in the three-phase system

Virtual lab:

- Spectrum analyser (FFT module)
- Frequency counter
- Multimeters (2x)
- Function generator
- Digital memory oscilloscope
- Multiplexer for recording four voltages and four currents

Additional functions:

- Word processing
- Printer
- Pocket calculator
- Free experimentation
- Glossary

The experiment board is located in a stable course frame. The Master Unit is pushed onto the course frame and connected to the board. The security lock ensures safe communication.

The experiment board is powered by the Master Unit.

The wiring of the experiments carried out over 2 mm cable.

Course content, experiment instructions and tasks are taught through a course-specific software.

Technical Specifications:

- Star circuit with resistors
- Delta circuit with resistors
- Capacitors
- Load resistors

700 2401	COM3LAB course: Three-phase technology
----------	--

Additionally required:

Count	Cat.No	Name
1	700 00CBTEN	DVD: COM3LAB software, English
1	700 020	COM3LAB Master Unit
1	700 022	Safety cable 2mm
1		PC with Windows XP/Vista/7/8

- Prerequisites: Fundamentals of AC technology





COM3LAB course: Electrical machines I

Course concerning the connection methods and the recording of characteristics for electric motors and generators. With the integrated machine test system, a multitude of experiments can be carried out, e.g. the recording of torque, power and current-locus curves.

Topics:

- Forces in a magnetic field
- Measurement of Lorentz force
- Drives
- Torque-speed characteristic
- Machine test system
- DC machines
- Speed and induced voltage with DC machines
- Torque and armature voltage with DC machines
- Torque and excitation voltage with DC machines
- DC machines with external excitation
- Reversible of direction
- Characteristics with variable armature voltage
- Characteristics with variable excitation voltage
- Shunt-wound DC machines
- Characteristics with variable operating voltage
- Series-wound DC machines
- Reversal of direction with DC machines
- Characteristics with variable operating voltage
- Generator operation of DC machines
- Drive and generator with a resistive load
- Power output of generator
- Rotating field (three-phase) machines
- Three-phase windings
- Rotating fields
- Direction of rotation with periodic swapping of phase conductors
- Direction of rotation when phase conductors are swapped
- Voltage and current in star (Y) circuits
- Voltage and current in delta circuits
- Resistance in stator winding
- Reactance of an AC winding
- Synchronous machines
- Equivalent circuit diagram for synchronous machines and how they are used
- Permanently excited synchronous machines
- Step operation of synchronous machines
- Determining rotor position in star configuration
- Determining rotor position in delta configuration
- Synchronous machine at variable speed (run-up)
- Speed measurement
- Speed setting using frequency converter
- Asynchronous machines
- Block and equivalent circuit diagrams for asynchronous machines
- Determination of slip
- Star-delta starting
- Measurement of torque and line currents during run-up
- Changing direction of asynchronous machines
- Recording of torque-speed characteristic for asynchronous machines
- Three-phase drives
- Changing speed of asynchronous machines
- How speed depends on slip
- How speed depends on stator frequency
- Stepper motors
- Full-step operation
- Half-step operation
- Changing the direction of a stepper motor

Virtual lab:

- Multi-channel oscilloscope
- Oscilloscope
- Function generator
- Multimeter (2x)
- Digital analyser

Additional functions:

- Word processing
- Printer
- Pocket calculator
- Free experimentation
- Glossary

The experiment board is located in a stable course frame. The Master Unit is pushed onto the course frame and connected to the board. The security lock ensures safe communication.

The experiment board is powered by the Master Unit.

The wiring of the experiments carried out over 2 mm cable.

Course content, experiment instructions and tasks are taught through a course-specific software.

Technical Specifications:

- Synchronous machine with optical rotary field indicator and strobe for speed determination
- Induction motor with star-delta switch
- Optical tachogenerator
- DC motor
- DC generator
- Current-torque converter
- Thermometer
- Electronic load
- Three phase generator, phase voltage: 0 V .. 10 V,
- Frequency converter, Frequency: 1 Hz - 80 Hz
- DC supplies
- Stepper motor
- Electrodynamic force meter
- Multichannel oscilloscope

Scope Of Delivery:

- Power supply 230/12 VAC

700 2501	COM3LAB course: Electrical machines I
----------	---------------------------------------

Additionally required:

Count	Cat.No	Name
1	700 00CBTEN	DVD: COM3LAB software, English
1	700 020	COM3LAB Master Unit
1	700 022	Safety cable 2mm
1		PC with Windows XP/Vista/7/8



COM3LAB Course: Automation and bus technology

The COM3LAB course automation and bus technology teaches the basic knowledge of programmable logic controller (PLC) and shows its networking including sensors and actuators by means of the PROFIBUS. With many examples, explanations, practices and practical tasks the base and mode of operation of the PLC and PROFIBUS are vividly represented.

It consists of an experiment board with various circuits for mounting into the Master Unit and a Multimedia CD with interactive training software.

Topics:

- Basics and basic terms (IEC 1131) of the PLC
- Logic connections, times, counters, data processing and program editing
- Simple sensors and signal conditioning with analogue digital transformers and multiplexers
- Projecting of an automatization system
- Programming and initiation of the PLC
- Data transfer structures and protocols
- Transfer and error analysis
- Connection of external components
- Link of PROFIBUS users (GSD)

Virtual lab:

- Oscilloscope
- Function generator
- Multimeter (2x)
- PROFIBUS analyser
- PLC Control
- PLC Program
- Process In/Out

Additional functions:

- Word processing
- Printer
- Pocket calculator
- Free experimentation
- Glossary

The experiment board is located in a stable course frame. The Master Unit is pushed onto the course frame and connected to the board. The security lock ensures safe communication.

The experiment board is powered by the Master Unit.

The wiring of the experiments carried out over 2 mm cable.

Course content, experiment instructions and tasks are taught through a course-specific software.

Technical Specifications:

- 24 digital inputs
- 8 analog inputs
- Sensors: Temperature sensor, Photo transistor
- 20 digital outputs
- 2 analog outputs
- 1 Motor
- Dimmable incandescent lamp
- 4 mm sockets for external application
- Connection for external Profibus components
- PROFIBUS (1 Master, 2 Slaves)

700 3101	COM3LAB Course: Automation and bus technology
----------	---

Additionally required:

Count	Cat.No	Name
1	700 00CBTEN	DVD: COM3LAB software, English
1	700 020	COM3LAB Master Unit
1	700 022	Safety cable 2mm
1		PC with Windows XP/Vista/7/8

COM3LAB Course: Electropneumatics

The COM3LAB course electro pneumatics is designed to teach basic knowledge of pneumatics and electro pneumatics. By means of examples, explanations, exercises and the complete range of BIBB standard tasks the basics and the „how-to“ of pneumatics and electro pneumatics are vividly illustrated.

In order to perform experiments the COM3LAB board can either be connected with industry standard valve technology or with the additionally available COM3LAB board pneumatics (700 351), which is equipped with complete hardware to perform all BIBB standard tasks. .

Topics:

- Basics of pneumatics/electro pneumatics
- Pneumatic and electric circuit diagrams
- Pilot control of a single-acting cylinder
- Pilot control of a double-acting cylinder
- Holding element control
- Basic circuit with AND function
- Basic circuit with OR function
- Basic circuit with electric latching circuits
- Displacement-dependent control
- Time-dependent control, switch-on and switch-off time delay
- Pressure-dependent control
- Sequential controls

Virtual lab:

- Oscilloscope
- Function generator
- Multimeters (2x)
- Digital analyser

Additional functions:

- Word processing
- Printer
- Pocket calculator
- Free experimentation
- Glossary

The experiment board is located in a stable course frame. The Master Unit is pushed onto the course frame and connected to the board. The security lock ensures safe communication.

The experiment board is powered by the Master Unit.

The wiring of the experiments carried out over 2 mm cable.

Course content, experiment instructions and tasks are taught through a course-specific software.

Technical Specifications:

- 6 relays, 4 changeover contacts
- 1 time relay (switch-on and switch-off time delay)
- 1 Pressure transducer
- 1 Pressure sensor 0 .. 10 bar
- Operating and monitoring elements
- 24 V voltage supply

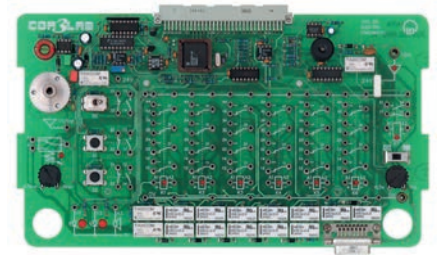

700 3501	COM3LAB Course: Electropneumatics
----------	-----------------------------------

Additionally required:

Count	Cat.No	Name
1	700 00CBTEN	DVD: COM3LAB software, English
1	700 020	COM3LAB Master Unit
1	700 022	Safety cable 2mm
1		PC with Windows XP/Vista/7/8

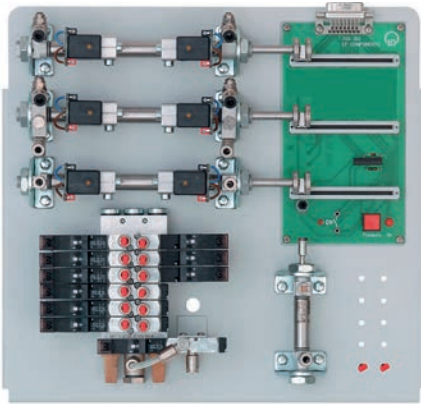

COM3LAB Course: Pneumatics Board

Addition to the COM3LAB course electropneumatics. The COM3Lab pneumatics board is equipped with the complete hardware to perform all BIBB standard tasks. It will be connected directly to the COM3LAB course electropneumatics that will monitor the components with the integrated displacement sensors of the cylinders.

Additionally required:

- 700 35 COM3LAB electropneumatics course
- Compressor with the following minimum requirements:
Connection power: 15 W
Pressure: 500 kPa
Feed rate: 2 l/min
- The quiet compressor Cat. no. 744 600 is recommended.

Technical Specifications:

- 1 x single-acting cylinder, spring return with capacitive end switch
- 3 x double-acting cylinder with displacement sensor and cylinder switch
- 4 x throttle valves
- 3 x 5/2 electric displacement impulse valves
- 3 x 5/2 electric displacement valves with spring return
- 1 x central switch-on valve for pressure supply, controlled by COM3LAB
- 3 x displacement sensor for double-acting cylinders

Scope Of Delivery:

- 1 x PU Plastic hose 5m long and 2.5 mm thick
- 6 x adapter cables 2 mm on socket connectors
- 20 x blanking elements
- 10 x 2 mm cables in blue, 4 cm long
- 20 x 2 mm cables in blue, 15 cm long
- 12 x 2mm cables in red/black, different lengths
- 1 x screwdriver

700 351	COM3LAB Course: Pneumatics Board
---------	----------------------------------

Additionally required:

Count	Cat.No	Name
1	700 3501	COM3LAB Course: Electropneumatics

Additionally recommended:

Count	Cat.No	Name
1	744 600	Low Noise Compressor

COM3LAB course: Microcontroller I

The COM3LAB course Microcontroller I deals with the construction, the function, the starting up and the programming of the microcontroller AT90CAN128 of the company Atmel. With animations and graphics the construction and the function of the AT90CAN128 is clearly described and explained.

Many examples and exercises familiarise to the computer languages assembler and C.

Topics

- Basics (CPU, RAM, ROM, timer, in/output, interrupt,...)
- Programming (computer languages, ISP and Jtag, interfaces, software, initialisation, debugger)
- AT90CAN128
- Assembler
- C
- Exercises (input, processing, output, subprograms, interrupt, timer, frequency, PWM, etc.)
- Application: traffic light control

Virtual lab:

- AVR Terminal
- LD4AVR

The microcontroller board of the COM3LAB course 700 36 Microcontroller I is directly connected to the PC via a USB cable.

Technical Specifications:

- 1 x AT90CAN128
- 1 x Module: 7-segment display
- 1 x Module: Digital I/O
- 1 x Module: traffic lights

Scope Of Delivery:

- 1 x Storage tray for storing the boards
- 1 x COM3LAB MCT mounting panel
- 3 x set of connecting cables (2 mm)
- 4 x ribbon cables (10 pol)
- 1 x Plug-in unit (12V/1,65A, 230V)
- 1 x USB cable
- 1 x Course software (CD)

700 36	COM3LAB course: Microcontroller I
--------	-----------------------------------

Additionally required:

Count	Cat.No	Name
1		PC with Windows XP/Vista/7/8

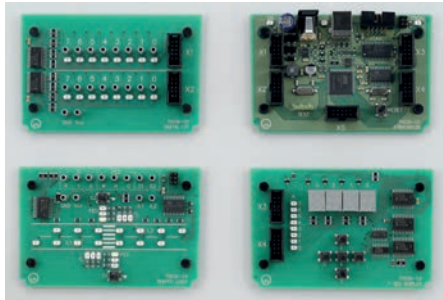

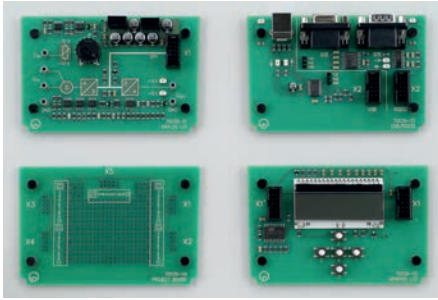

COM3LAB course: Microcontroller II

The COM3LAB course Microcontroller II continues with the subjects of the COM3LAB course Microcontroller I. On basis of many animations and pictures the knowledge in microcontroller programming is enhanced. Many examples and exercises broaden programming skills in C.

Topics:

- Initialisation and programming
- Fundamentals SPI
- Source and header files
- Projects
- Analog I/O
- Graphic display
- USB / RS232
- Projects

Virtual lab:

- AVR terminal
- LD4AVR

Technical Specifications:

- **Analog I/O**
There are various analog components on this board, which can be operated using the microcontroller.
- **Graphic display**
1 Graphic LCD (132 x 32 Pixel, 55 x 31 mm², Background lighting amber)
5 sensors
- **USB / RS232**
1 USB B connection
1 RS232 socket (9-pole)
1 RS232 plug (9-pole)
(USB and RS232 can be optionally used)
- **Project**
This board is a development board for personal projects.
Some circuits are soldered on the board and controlled with the 70036 Microcontroller AT90CAN128.

Scope Of Delivery:

- 2 x Adapter cables (2 to 4 mm)
- 1 x V24 cable (9-pole)
- 1 x USB cable
- 1 x Course software (CD)

700 39	COM3LAB course: Microcontroller II
--------	------------------------------------

Additionally required:

Count	Cat.No	Name
1		PC with Windows XP/Vista/7/8

COM3LAB course: Photovoltaic

Photovoltaic bases

The COM3LAB course 700 53 photovoltaic treats the structure and the function of solar cells. Animations and illustrations give a descriptive introduction into photovoltaic systems. On basis of real experiments, the course describes the functioning of solar modules. The microcontrolled charge controller pursues the solar generator in the Maximum Power Point (MPP). Theory and experiments are accompanied and checked by the photovoltaic interactive training program.

Topics:

- Solar cell (Properties, function, etc)
- Solar module (Properties, function, etc)
- Different circuits of solar modules
- Solar characteristic
- Influence of temperature
- Influence of shadow
- Charge controller
- Solar charger controller
- Photovoltaic systems
- Applications

Virtual lab:

- Oscilloscope
- Function generator
- Multimeter (2x)
- Digital analyser

Additional functions:

- Word processing
- Printer
- Pocket calculator
- Free experimentation
- Glossary

The experiment board is located in a stable course frame. The Master Unit is pushed onto the course frame and connected to the board. The security lock ensures safe communication.

The experiment board is powered by the Master Unit.

The wiring of the experiments carried out over 2 mm cable.

Course content, experiment instructions and tasks are taught through a course-specific software.

Technical Specifications:

- 1 x Halogen lamp 230 V / 100 W with holder and dimmer
- 4 x Solar cells 4 V / 35 mA
- 1 x Solar charger 2.4 V / 60 mAh
- 1 x Solar controller with microcontroller
- 1 x Solar controller with IC
- 1 x Temperature sensor
- 1 x Fan 12 V
- 1 x Step-up converter
- 1 x Frequency converter
- 2 x Current/Voltage converter
- 1 x Motor
- 1 x LED 12 V
- 2 x Storage capacitors
- 1 x Ohmic load

700 5301	COM3LAB course: Photovoltaic
----------	------------------------------

Additionally required:

Count	Cat.No	Name
1	700 00CBTEN	DVD: COM3LAB software, English
1	700 020	COM3LAB Master Unit
1	700 022	Safety cable 2mm
1		PC with Windows XP/Vista/7/8





COM3LAB Course: Automotive technology I

This COM3LAB course prepares and teaches the basics of automotive electrics/electronics in a comprehensible manner. Physical, chemical and mathematical properties of „Electricity“ lead to a comprehensive understanding of the electrical processes and events in vehicles. Measuring technology, troubleshooting and fault correction complete the learning content.

Topics:

- Electricity in the vehicle: current - voltage - resistance
- Calculating with parameters: Ohm's law - Power
- Circuits
- Series and parallel circuits - forward slope resistances

Virtual lab:

- Oscilloscope
- Function generator
- Multimeter (2x)
- Digital analyser

Additional functions:

- Word processing
- Printer
- Pocket calculator
- Free experimentation
- Glossary

The experiment board is located in a stable course frame. The Master Unit is pushed onto the course frame and connected to the board. The security lock ensures safe communication.

The experiment board is powered by the Master Unit.

The wiring of the experiments carried out over 2 mm cable.

Course content, experiment instructions and tasks are taught through a course-specific software.

Technical Specifications:

- Circuit and relay
- Analog multimeter
- Resistances
- Solar cell
- Diodes
- On-board electrical system and lighting

Scope Of Delivery:

- 1 x Wire wrap panel
- 1 x Chrome nickel wire (d=0.2mm/l=3m)
- 1 x Constantan wire (d=0.2mm/l=3m)
- 1 x Iron wire (d=0.2mm/l=3m)
- 2 x Adapter cables (2 to 4 mm)
- 1 x set of connecting cables (2 mm)

700 6101	COM3LAB Course: Automotive technology I
----------	---

Additionally required:

Count	Cat.No	Name
1	700 00CBTEN	DVD: COM3LAB software, English
1	700 020	COM3LAB Master Unit
1	700 022	Safety cable 2mm
1		PC with Windows XP/Vista/7/8

COM3LAB Vehicle Sensors

This CBT course prepares and teaches advanced principles of automotive electrics/electronics in a comprehensible manner. The physical, chemical and mathematical properties of „Electricity“ lead to a comprehensive understanding of the electrical processes and events in vehicles. Measuring technology, troubleshooting and fault correction complete the learning content.

Topics:

- Components: switches, resistors, capacitors, diodes and Zener diodes, relays.
- Schematics: reading vehicle schematics
- Sensors: inductive sensors, magnetic-field sensors.
- Batteries and accumulators: Interconnecting cells, accumulator types.
- Ignition: capacitors, relays, induction, ignition coil.
- Generators and motors: rectification, three-phase generator, permanent magnet generator.
- Transistors in the vehicle: transistor, checking transistors,
- Monitoring features in vehicles, amplifier circuits, application circuits.

Virtual lab:

- Oscilloscope
- Function generator
- Multimeter (2x)
- Digital analyser

Additional functions:

- Word processing
- Printer
- Pocket calculator
- Free experimentation
- Glossary

The experiment board is located in a stable course frame. The Master Unit is pushed onto the course frame and connected to the board. The security lock ensures safe communication.

The experiment board is powered by the Master Unit.

The wiring of the experiments carried out over 2 mm cable.

Course content, experiment instructions and tasks are taught through a course-specific software.

Technical Specifications:

- Components: diodes, coil,
- Capacitor, circuit, transistor
- Adjustable fan, rev counter
- Transistor circuits
- Bridge rectifier circuit
- Motor / Generator



700 6201	COM3LAB Vehicle Sensors
----------	-------------------------

Additionally required:

Count	Cat.No	Name
1	700 00CBTEN	DVD: COM3LAB software, English
1	700 020	COM3LAB Master Unit
1	700 022	Safety cable 2mm
1		PC with Windows XP/Vista/7/8



COM3LAB Course: Automotive Data Buses

In this CBT course, the interconnected electronic systems in automotive technology are comprehensively prepared and taught. At the forefront of this is getting to know the various bus systems and their application areas. Here, action-oriented tasks lead to a comprehensive understanding of the connections in the vehicle. Measuring technology as well as troubleshooting and fault correction complete the learning content.

In conjunction with the *CAN databus adapter USB, 739 581USB* and the *LIN bus PC interface USB, 739 588* the following topics can be covered:

- Digital technology: Basics of the digital technology
- Bus systems: CAN, LIN, SENT
- Measuring technology: physical signals, protocols, fault analysis
- Connection with external components feasible
- Other applications and system components

The experiment board is located in a stable course frame. The Master Unit is pushed onto the course frame and connected to the board. The security lock ensures safe communication.

The experiment board is powered by the Master Unit.

The wiring of the experiments carried out over 2 mm cable.

Course content, experiment instructions and tasks are taught through a course-specific software.

700 6301	COM3LAB Course: Automotive Data Buses
----------	---------------------------------------

Additionally required:

Count	Cat.No	Name
1	700 00CBTEN	DVD: COM3LAB software, English
1	700 020	COM3LAB Master Unit
1	700 022	Safety cable 2mm
1		PC with Windows XP/Vista/8

Available starting October 2014

COM3LAB Course: Vehicle fundamentals Digital and Bus Technology

of switch algebra are dealt with using logic links. Animations and interactions make the fundamentals of modern bus systems clear. The topic areas are practical and adapted to the automotive technology in terms of application.

Topics:

- TTL-AND
- TTL-OR
- TTL-NOT
- TTL-XOR
- TTL-NAND
- Boolean operations
- Coding
- Multiplexer
- Fundamentals CAN Bus

Virtual lab:

- Oscilloscope
- Function generator
- 2 Multimeters
- Digital analyzer

Additional function:

- Word processing
- Printer
- Pocket calculator
- Free experimentation
- Glossary

The experiment board is located in a stable course frame. The Master Unit is pushed onto the course frame and connected to the board. The security lock ensures safe communication.

The experiment board is powered by the Master Unit.

The wiring of the experiments carried out over 2 mm cable.

Course content, experiment instructions and tasks are taught through a course-specific software.

Technical Specifications:

- 4 x AND, 3 x OR, 2 x XOR, 2 x NOR, 3 x NAND
- Full adder
- 7-segment display
- Multiplexer, Demultiplexer
- 4 command switch
- 2 sensors, 2 LEDs

Scope Of Delivery:

- Cable set consisting of 5, 30 cm connecting cables with 2 mm plugs.

700 6401	COM3LAB Course: Vehicle fundamentals Digital and Bus Technology
----------	---

Additionally required:

Count	Cat.No	Name
1	700 00CBTEN	DVD: COM3LAB software, English
1	700 020	COM3LAB Master Unit
1	700 022	Safety cable 2mm
1		PC with Windows XP/Vista/7/8



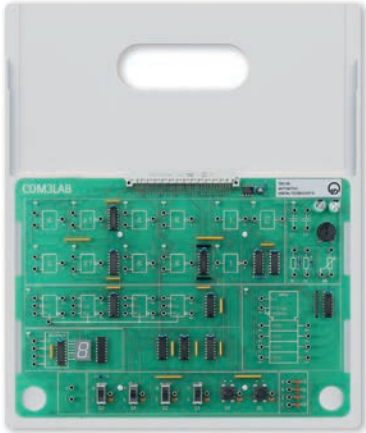

COM3LAB Course: Automotive Digital Technology II

In the COM3LAB course Digital technology for vehicle occupations, the fundamentals of switch algebra are dealt with using logic links. Animations and interactions make the fundamentals of modern bus systems clear. The topic areas are practical and adapted to the automotive technology in terms of application.

Topics:

- Flip-flop
- RS flip-flop
- JK flip-flop
- Shift register
- Counter
- Multivibrators
- Impulse diagram

Virtual lab:

- Oscilloscope
- Function generator
- 2 Multimeters
- Digital analyser

Additional function:

- Word processing
- Printer
- Pocket calculator
- Free experimentation
- Glossary

The experiment board is located in a stable course frame. The Master Unit is pushed onto the course frame and connected to the board. The security lock ensures safe communication.

The experiment board is powered by the Master Unit.

The wiring of the experiments carried out over 2 mm cable.

Course content, experiment instructions and tasks are taught through a course-specific software.

Technical Specifications:

- 2 x AND, 2 x NOR, 4 x NAND
- 2 Inverter
- 1 Schmitt trigger
- 1 7-segment display
- 4 JK flip-flop
- 1 Universal shift register
- 4 Command switch,
- 2 sensors, 4 LEDs

700 6501	COM3LAB Course: Automotive Digital Technology II
----------	--

Additionally required:

Count	Cat.No	Name
1	700 00CBTEN	DVD: COM3LAB software, English
1	700 020	COM3LAB Master Unit
1	700 022	Safety cable 2mm
1		PC with Windows XP/Vista/7/8

COM3LAB Course: Transmission Technology TX433

Course on the fundamentals and applications of radio transmission technology and analog modulation technology, consisting of an experiment board with various circuits for mounting into the multimedia basic unit and a Multimedia CD with an interactive training software.

Topics:

- Introduction;
- Measuring techniques, spectrum and network analysis;
- Design of transmitters;
- Beats;
- Double sideband AM;
- Single sideband AM;
- Frequency modulation;
- Stereophonics and RDS;
- Coding; shift-keying ASK, FSK, PSK;
- Matching;
- The transmitting antenna, SWR measurements;
- Digital data;
- Fault simulation

In conjunction with an additional Master Unit and the receiving technology course the following experiments can also be performed:

- Signal transmission;
 - transmission of alpha-numeric data;
 - telematics,
 - telemetry,
 - cryptography

Virtual lab:

- Oscilloscope
- Function generator
- 2 Multimeters
- Digital analyser
- Spectrum analyser (FFT-module)
- Network analyser with Bode module
- SWR meter
- Frequency counter
- Data transfer module

Additional functions:

- Word processing
- Printer
- Pocket calculator
- Free experimentation
- Glossary

The test board is located in a stable course frame. The Master Unit is pushed onto the course frame and connected to the board. The security lock ensures safe communication.

The experiment board is powered by the Master Unit. The wiring of the experiments is carried out using a 2 mm cable. Course content, experiment instructions and tasks are taught through a course-specific software.

Note

Runs under Windows 2000/XP/Vista/7/8 (32 Bit only)

Technical Specifications:

- Signal generator, Summing output stage
- Carrier oscillator, Product modulator (AM), ESB filter
- Matching element
- Stereo / Mono converter
- VCO with pre-emphasis (FM)
- Stereocoder, RDS coder
- FM transmitter in Hybrid module technology (SMD)
 - Transmission frequency: 433,75 MHz, approval-free ISM frequency
 - Power: 10 mW
- Frequency hub: adjustable, max. 75 kHz
 - Telescopic aerial, Directional coupler
 - Evaluation electronics (SWR)
 - Calibration element: 50 Ω BNC

Scope Of Delivery:

- Telescopic w with BNC socket
- BNC end-plug 50 Ohm



700 7101	COM3LAB Course: Transmission Technology TX433
----------	---

Additionally required:

Count	Cat.No	Name
1	700 00CBTEN	DVD: COM3LAB software, English
1	700 020	COM3LAB Master Unit
1	700 022	Safety cable 2mm
1		PC with Windows XP/Vista/7/8

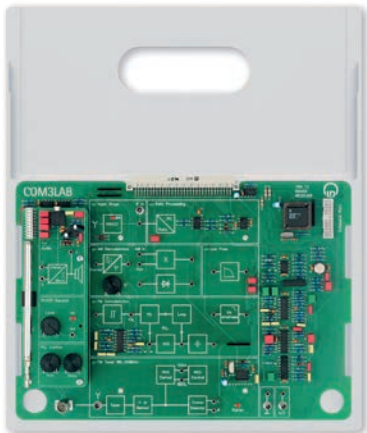

COM3LAB Course: Reception Technology RX433

Expansion course to 700 71 COM3LAB course TX433 Transmitting Technology. This course contains the fundamentals and applications of radio receiving technology and analogue demodulation technology. The experiments are performed with the board of the transmitter and the receiver. The course consists of an experiment board with various circuits for mounting into the Master Unit.

Topics:

- Receiver concepts
- Measurement techniques
- Sound equalizing
- Radio receiver
- Applications of RDS, service features and information types
- Stereo reproduction
- Synchronous demodulation
- Envelope curve demodulation
- PLL
- De-emphasis
- Encoding
- Data security
- Fault simulation

In conjunction with an additional Master Unit and the transmission technology course the following experiments can also be performed:

- Demodulation of AM and FM signals
- How squelch works
- Signal transmission
- Transmission of alphanumeric data
- Telematics, telemetry, cryptography

Virtual Lab:

- Oscilloscope
- Function generator
- 2 Multimeters
- Digital analyser
- Spectrum analyser (FFT-module)
- Network analyser with Bode module
- Data transfer module

Additional functions:

- Word processing
- Printer
- Pocket calculator
- Free experimentation
- Glossary

The test board is located in a stable course frame. The Master Unit is pushed onto the course frame and connected to the board. The security lock ensures safe communication.

The experiment board is powered by the Master Unit. The wiring of the experiments is carried out using a 2 mm cable. Course content, experiment instructions and tasks are taught through a course-specific software.

Note

Runs under Windows 2000/XP/Vista/7/8 (32 Bit only)

Technical Specifications:

- FM tuner 88...108 MHz with RDS function
- Stereo decoder
- Superhet in hybrid module technology (SMD)
- Reception frequency: 433,75 MHz, approval-free ISM frequency
- Audio bandwidth: 20 kHz
- Synchronous demodulator
- Band filter for carrier regeneration
- Variable phase shifter
- Envelope demodulator
- Demodulator low-pass
- PLL, De-emphasis
- Audio stage with sound corrector
- Output stage with loudspeaker
- Data processing unit
- Telescopic aerial

700 7201	COM3LAB Course: Reception Technology RX433
----------	--

Additionally required:

Count	Cat.No	Name
1	700 00CBTEN	DVD: COM3LAB software, English
1	700 020	COM3LAB Master Unit
1	700 022	Safety cable 2mm
1		PC with Windows XP/Vista/7/8

COM3LAB Course: Digital Communication Technology

The COM3LAB course: Digital Communication Technology discusses all topics of digital signal processing. Additionally attention is paid to the realisation and function of fibre optic transmission systems.

Emphasis is laid upon the applications of PCM technology, e.g.: Transmission of voice and signals with real telephones, sound cards, CD-players etc. .

Topics:

- Characteristics of pulse carriers
- Generation of PAM
- PAM (natural)
- PAM (S&H)
- PAM spectrum
- Over sampling / under sampling
- Aliasing
- Shannon theorem
- Pulse code modulation (PCM)
- Quantisation linear and nonlinear
- Compression / expanding
- Code errors
- Time division multiplexing (TDM)
- Synchronisation
- Quantisation noise
- Difference pulse code modulation (DPCM)
- Optical signal transmission
- Signal transmission by wire (coaxial line / two-wire line)
- Simplex / duplex communication

Options

- Transmission of voice (requires external signals, CD player, telephones etc.)
- Influence of the trigger and type of quantisation on the speech intelligibility
- Duplex communication (requires 2 x COM3LAB Course PCM technology, as well as external signal sources)

Virtual Lab:

- Oscilloscope
- Function generator
- 2 Multimeters
- Digital analyser
- Spectrum analyser (FFT-module)
- Frequency counter

Additional functions:

- Word processing
- Printer
- Pocket calculator
- Free experimentation
- Glossary

The test board is located in a stable course frame. The Master Unit is pushed onto the course frame and connected to the board. The security lock ensures safe communication.

The experiment board is powered by the Master Unit. The wiring of the experiments is carried out using a 2 mm cable. Course content, experiment instructions and tasks are taught through a course-specific software.

Technical Specifications:

- 2 x PAM Modulator
- 2 x PCM Modulator
- Clock-pulse generator
- 2 x PAM Demodulator
- 2 x PCM Demodulator
- Signal source Sinus, 1 kHz
- Signal source Sinus, 2 kHz
- RJ-12 socket with hybrid termination circuit
- Jack bush for connecting external signal sources
- Jack bush for connecting external active speakers
- Optical transmitter
- Optical receiver
- Fibre-optic cable with plugs, 3 m

Scope Of Delivery:

- 1 x Audio connection cable (jack bush 3.5 mm)
- 1 x fibre-optic cable (3 m)



700 7301	COM3LAB Course: Digital Communication Technology
----------	--

Additionally required:

Count	Cat.No	Name
1	700 00CBTEN	DVD: COM3LAB software, English
1	700 020	COM3LAB Master Unit
1	700 022	Safety cable 2mm
1		PC with Windows XP/Vista/7/8



COM3LAB Course: Modem Technology

Course on the fundamentals and applications of shift keyed signals and modems, consisting of an experiment board with various circuits for mounting into the Master Unit.

Topics:

- Introduction
- Amplitude shift keying (ASK)
- Frequency shift keying
- 2-Phase shift keying (2PSK)
- 4-Phase shift keying (4PSK)
- Difference phase coding
- Shift keyed signals in the time domain
- Shift keyed signals in the frequency domain
- Estimation of the bandwidth
- Modulation rate / data rate
- SNR and bandwidth
- Hardware of the modulators
- Hardware of the demodulators
- Carrier recovery and synchronisation of the demodulators
- Error correction
- Error detection
- Operational modes: simplex half duplex, full duplex
- NRZ Line code
- Fault simulation

Options:

- Communication of 2 PCs using modems
A 2nd workstation with a PC with Master Unit and modem technology course (700 7401) is necessary, as well as other accessories (coaxial cable, star quad cable etc.)

Virtual Lab:

- Oscilloscope
- Function generator
- 2 Multimeters
- Digital analyser
- Spectrum analyser (FFT-module)
- Frequency counter
- Data transfer module

Additional functions:

- Word processing
- Printer
- Pocket calculator
- Free experimentation
- Glossary

The test board is located in a stable course frame. The Master Unit is pushed onto the course frame and connected to the board. The security lock ensures safe communication.

The experiment board is powered by the Master Unit. The wiring of the experiments is carried out using a 2 mm cable. Course content, experiment instructions and tasks are taught through a course-specific software.

Technical Specifications:

- Data source for baseband signal
- ASK Modulator
- FSK Modulator
- 2PSK Modulator
- 4PSK Modulator
- Carrier generator
- Modulation multiplexer
- Audio stage with piezo loudspeaker
- Channel level adapter
- Signal detector
- ASK demodulator
- FSK demodulator
- 2PSK demodulator
- 4PSK demodulator
- Carrier recovery

700 7401	COM3LAB Course: Modem Technology
----------	----------------------------------

Additionally required:

Count	Cat.No	Name
1	700 00CBTEN	DVD: COM3LAB software, English
1	700 020	COM3LAB Master Unit
1	700 022	Safety cable 2mm
1		PC with Windows XP/Vista/7/8

COM3LAB Course: Telecommunication Lines

Course on the fundamentals and applications of various telecommunication line types.

Topics:

- Frequency responses of two-wire lines
- Determination of the characteristic wave impedance
- Measurement of near and far-end crosstalk
- Impulse behaviour of coaxial lines
- Mismatching
- Hybrid and phantom circuit
- Duplex transmission and remote supply
- Characteristic curves of LEDs in the optical communications engineering
- Attenuation at fibre optic lines
- Measurement of the optical power
- Coupling losses
- Bending losses

Virtual Lab:

- Oscilloscope
- Function generator
- 2 Multimeters
- Digital analyser
- FFT Spectrum analyser
- Frequency counter
- Bode module

Additional functions:

- Word processing
- Printer
- Pocket calculator
- Free experimentation
- Glossary

The test board is located in a stable course frame. The Master Unit is pushed onto the course frame and connected to the board. The security lock ensures safe communication. The experiment board is powered by the Master Unit. The wiring of the experiments is carried out using a 2 mm cable. Course content, experiment instructions and tasks are taught through a course-specific software.

Technical Specifications:

- Equivalent circuits of two-wire lines
- Equivalent line of four-wire lines
- Star quad with phantom circuit
- Hybrid termination circuit
- Pulse generator
- Module for echo pulse evaluation
- Optical transmitter
- Optical level meter
- Shift unit for longitudinal offset on fibre-optic cable
- Signal sources 1 kHz / 2 kHz

Scope Of Delivery:

- 1 x coaxial cable, 50 m of RG 58 manufactures with BNC plug / plug
- 1 x fibre optic cable, 2 m
- 1 x fibre optic cable, 20 m

700 7501	COM3LAB Course: Telecommunication Lines
----------	---

Additionally required:

Count	Cat.No	Name
1	700 00CBTEN	DVD: COM3LAB software, English
1	700 020	COM3LAB Master Unit
1	700 022	Safety cable 2mm
1		PC with Windows XP/Vista/7/8





COM3LAB Course: Operational amplifier

Course on operational amplifier circuits, consisting of an experiment board with various circuits for mounting into the Master Unit.

Topics:

- The comparator
- Features of the operational amplifier
- Inverting op amp
- Noninverting op amp
- Fault simulation in inverting op amps
- Adder
- Integrator
- Differentiator
- Active filters
- Stabilised voltage source
- Stabilised current source
- Schmitt trigger
- Astable multivibrator
- Wien bridge oscillator
- Function generator

Virtual Lab:

- Oscilloscope
- Function generator
- 2 Multimeters
- Digital analyser
- FFT Spectrum analyser
- Frequency counter
- Bode module

Additional functions:

- Word processing
- Printer
- Pocket calculator
- Free experimentation
- Glossary

The test board is located in a stable course frame. The Master Unit is pushed onto the course frame and connected to the board. The security lock ensures safe communication.

The experiment board is powered by the Master Unit. The wiring of the experiments is carried out using a 2 mm cable. Course content, experiment instructions and tasks are taught through a course-specific software.

700 8101	COM3LAB Course: Operational amplifier
----------	---------------------------------------

Additionally required:

Count	Cat.No	Name
1	700 00CBTEN	DVD: COM3LAB software, English
1	700 020	COM3LAB Master Unit
1	700 022	Safety cable 2mm
1		PC with Windows XP/Vista/7/8

COM3LAB course: Control technology I

Course on the fundamentals of automatic control technology, consisting of an experiment board with various circuits for mounting into the Master Unit and a Multimedia CD with an interactive training program.

Topics:

- Introduction
- Open-loop control
- Closed-loop control
- Analysis of controlled systems
- Controlled systems with/without compensation
- Controlled systems of a higher order
- Types of controllers
- P, I, PI, PID and PD control
- Automatic digital control
- Performance criteria for automatic controls
- Optimization guidelines for PID controllers
- Automatic temperature control
- Automatic speed control
- Automatic light control
- Automatic control of systems without compensation
- Automatic control with discontinuous controllers
- Fault simulation

Virtual lab:

- Oscilloscope
- Function generator
- 2 Multimeters
- Digital analyser
- Static characteristic plotter
- Step response plotter
- DDC plotter
- Controller design calculator (for optimum controller parameters)

Additional functions:

- Word processing
- Printer
- Pocket calculator
- Free experimentation
- Glossary

The experiment board is powered by the Master Unit.

The wiring of the experiments carried out over 2 mm cable.

Course content, experiment instructions and tasks are taught through a course-specific software.

Technical Specifications:

- Analog controller
- Summation points with disturbance inputs
- Digital controller
- Lag element
- DC signal sources 1V, 5V, 10V
- P-action element
- PT-1 elements (2 x)
- I-action element, resettable
- Nonlinear characteristic element
- Speed controlled system with optical speed sensor
- Temperature controlled system with KTY-temperature sensor
- Light controlled system with photodiode sensor and external light source (disturbance source)

700 8201	COM3LAB course: Control technology I
----------	--------------------------------------

Additionally required:

Count	Cat.No	Name
1	700 00CBTEN	DVD: COM3LAB software, English
1	700 020	COM3LAB Master Unit
1	700 022	Safety cable 2mm
1		PC with Windows XP/Vista/7/8

- Operating system: Windows XP/Vista/7/8
- Support for unguided, free experimentation

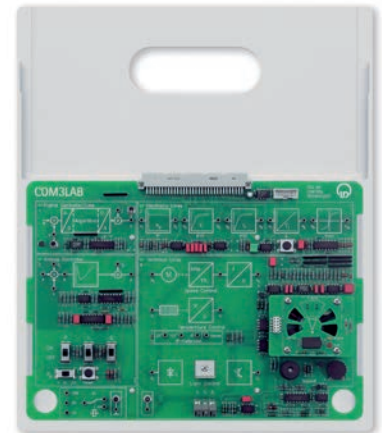



COM3LAB course: Control technology II

Supplementary course on the fundamentals of control technology including a dongle for the CTI experiment board.

Topics:

- Introduction
- Stability of automatic control systems
- Controller design using the Ziegler/Nichols method
- Systems with lag time
- Limiting the manipulated variable
- Cascade control
- Introduction to frequency response
- Frequency response of single basic elements
- Frequency response of combined elements
- Controller design in the frequency domain
- Fuzzy control
- Adaptive control
- Experiments with external controlled systems

Virtual lab:

- Oscilloscope
- Function generator
- 1 Multimeter
- Digital Analyser
- Static characteristic plotter
- Step response plotter
- DDC plotter
- Controller design calculator (for optimum controller parameters)

Additional Functions:

- Word processing
- Printer
- Pocket calculator
- Free experimentation
- Glossary

The 700 83 dongle is pushed onto the experiment board 700 82. This is powered by the Master Unit. The wiring of the experiments carried out over 2 mm cable.

Course content, experiment instructions and tasks are taught through a course-specific software.

700 83	COM3LAB course: Control technology II
--------	---------------------------------------

Additionally required:

Count	Cat.No	Name
1	700 00CBTEN	DVD: COM3LAB software, English
1	700 82	COM3LAB course: Control technology I

- Operating system: Windows XP/Vista/7/8
- Support for unguided, free experimentation.
- Additionally required:
 - 700 82 COM3LAB course, Control Technology I

COM3LAB Course: Sensor technology

This COM3LAB sensor system course (700 84) teaches the basics of the measurements of non-electric quantities. With many examples, explanations and practical tasks, the function and operation of sensors and measuring circuits are investigated.

Topics:

- Electronic circuits for temperature measurement
- Function and characteristics of different temperature sensors: Pt100, NTC, KTY and thermocouple.
- Function and characteristics of pressure sensors.
- Force measurements with strain gauges.
- Force measurement with bending bar.
- Displacement-, angle- and speed measurement.
- Measurements with optical encoder.
- Hall sensors.

Virtual lab:

- Frequency counter
- 2 digital multimeters
- Function generator
- Digital memory oscilloscope

Additional functions:

- Word processing
- Printer
- Pocket calculator
- Free experimentation
- Glossary

The test board is located in a stable course frame. The Master Unit is pushed onto the course frame and connected to the board. The security lock ensures safe communication.

The experiment board is powered by the Master Unit. The wiring of the experiments is carried out using a 2 mm cable. Course content, experiment instructions and tasks are taught through a course-specific software.

Technical Specifications:

- Torque measurement using strain gauges on beams
- Temperature sensors: Pt 100, NTC, KTY, Thermocouple element
- Peltier element for recording the temperature characteristics of approx. 0° to 50°
- Differential pressure sensor
- Ohmic displacement transducer
- Capacitive displacement transducer
- Inductive displacement transducer
- Positioning using hall sensor and Reed contact
- Ultrasonic sensor with receiver
- Brightness measurement using photo diode
- Hall sensor
- Optical sensor
- Adjustable current source
- Measuring procedure with compensated lines: three-wire measurement, four-wire measurement
- 1 universal measurement amplifier
- 1 pressure sensor with pressure display
- 1 force gauge

Scope Of Delivery:

- 1 x 50 ml nozzle
- 1 x pressure gauge 1 – 1.5 bar
- 1 x hose, 6 cm long
- 1 x hose connector
- 1 x compressive force gauge, 3 bar
- 1 x compression member

700 8401	COM3LAB Course: Sensor technology
----------	-----------------------------------

Additionally required:

Count	Cat.No	Name
1	700 00CBTEN	DVD: COM3LAB software, English
1	700 020	COM3LAB Master Unit
1	700 022	Safety cable 2mm
1		PC with Windows XP/Vista/7/8



Electina

ELECTINA (without PCB) is a powerful and flexible training, exercise and development package to design analogue and digital electronic circuits. Circuit diagrams are created using an easy-to-use design editor. The circuit simulations and circuit analyses, virtual or real time measurements as well as mistake search can easily be carried out with the quickly learnable tools of Electina.

Plain DTP tools as well as efficient text editors and equation editors help in the production of professional teaching materials, reports and presentations.

Electina contains efficient tools to control learning with pupils, to supervise the learning success and to know the technologies in the mistake search. Above the USB interface circuits on COM3LAB Protoboard can be analysed and evaluated by Electina. Version 8.

Properties

- Simply serveable circuit draught editor
- 3D view
- Editor to the easy construction of switch symbols and components from self-sketched or imported Spice Subcircuits
- Extensive libraries with Spice to models and more than 20,000 components
- More than 20 different analysis possibilities
- Measuring instruments for the simulation and real time measurement
- Digital multimeter
- Functional generator
- Memory oscilloscope
- XY recorder
- Signal analysers
- Digital signal generator
- Logic analysator
- Bode / Nyquist diagrams
- Results of analysis
- Pol-/zero places calculation
- Errors simulation
- Test board active 3D

Cat.No	Description
700 901-01	Electina Standard, COM3LAB support (1 license), German
700 901-11	Electina Design Suite, PCB, COM3LAB support (1 license), German
700 901-14	Electina Design Suite, PCB, COM3LAB Support (School licence), German
700 902-01	Electina Standard, COM3LAB support (1 license)
700 902-04	Electina Standard, COM3LAB support (school license)
700 902-11	Electina Design Suite, PCB, COM3LAB Support (1 licence)
700 902-14	Electina Design Suite, PCB, COM3LAB Support (School licence)

COM3LAB Protoboard II

Protoboard II expands the COM3LAB Master Unit into a development platform for electronic circuits. Any type of circuit with electronic components (not included) can be set up and tested on the breadboard with 1-mm contacts.

The fixed voltage outputs and the function generator output are connected via 2-mm sockets and can be switched using slide switches. There are 2 change-over switches for any desired connections located on the prototyping board. Furthermore, standard European printed circuit boards can be connected using a 64-pin VG terminal strip. 8 relay switchover contacts are located on the VG terminal strip. 8 digital outputs can be tapped using the VG strip or via 2-mm sockets. The relay and digital outputs can be switched using software.

The power supply, the multimeter and the function generator of the Master Unit can be operated without the PC.

Scope Of Delivery:

- Software for the display of the integrated measuring instruments (multimeter, function generator, memory oscilloscope, logic analyser, frequency counter) under Windows
- 2 European grid matrix printed circuit boards with VG plug for soldering exercises and for the assembly of special circuits
- 50 wire jumpers, 1 mm, for interconnecting the components
- 20 adapter leads, 1 mm/2 mm for the connection of the measuring points to the inputs of the measuring instruments
- 5 probe tips with 2-mm terminal socket

700 9101	COM3LAB Protoboard II
----------	-----------------------

Additionally required:

Count	Cat.No	Name
1	700 00CBTEN	DVD: COM3LAB software, English
1	700 020	COM3LAB Master Unit
1	700 022	Safety cable 2mm
1		PC with Windows XP/Vista/7/8



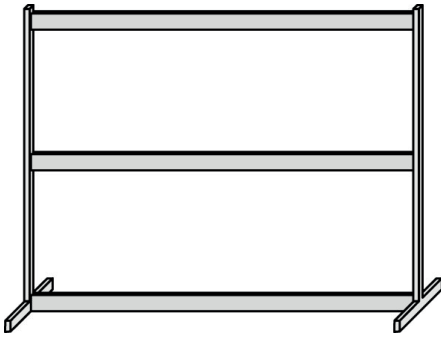

Panel frame T130, two-level

- two-level
- T-base
- without channel

Technical Specifications:

- Height: 73,0 cm
- Width: 124 cm
- Depth: 30 cm

726 09	Panel frame T130, two-level
--------	-----------------------------



Panel frame SL85, single-level

- Single-level frame for training panels of DIN A4 height, design with approx. 30° angle
- Two aluminium profile rails with 2 brush strips
- 2 L-shaped bases made of rectangular steel tubing

Technical Specifications:

- Table fastening with 2 M8 wing screws
- Width: 895 mm, Height: 380 mm, Depth: 250 mm

726 19	Panel frame SL85, single-level
--------	--------------------------------



Single-phase supply unit

To switch the mains voltage in experiments with electrical loads for AC voltage of 230 V.

Technical Specifications:

- Cam switch, 2-pole
- Automatic circuit breaker FAZ L 10 A Phase monitor light L 1
- Phase monitor light for indication of false polarity of mains plug

Scope Of Delivery:

- Mains connecting cable with earth-contact plug

726 71	Single-phase supply unit
--------	--------------------------

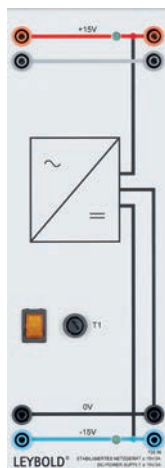

Stabilised power supply ± 15 V/3 A

Laboratory power supply with two separate and stabilised fixed voltages for vertical assembly in panel frames or demonstration experiment frames using the plug-in system. Short-circuit-proof. Rated-voltage monitoring via two green LEDs.

Technical Specifications:

- Output voltage: ± 15 V via 4-mm sockets
- Maximum load capacity: 2.4 A, short-term 3 A
- Connection voltage: 230 V, 50/60 Hz
- Fuse: T 1.0
- Power consumption: 160 VA
- Dimensions: 100 mm x 297 mm x 120 mm
- Weight: 5 kg

726 86	Stabilised power supply ± 15 V/3 A
--------	--

Software: 5 Models CBS 9 (single user)

Simulation that runs on the PC and contains the simulation of 5 different processes. Using a PROFI-CASSY Interface (524 016) this simulation can be controlled by a real PLC or the COM3LAB Course "Automation and Bus technology".

This package contains a Single user license with the following models:

- Motor control
- Traffic light control
- Liquid level control
- Service lift
- Stamping machine

728 871	Software: 5 Modells CBS 9 (single user)
---------	---

Available in German or Spanish

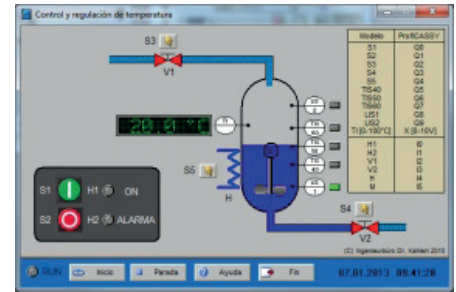

Software: 5 Models CBS 9 (licence for 25 places)

Simulation that runs on the PC and contains the simulation of 5 different processes. Using a PROFI-CASSY Interface (524 016) this simulation can be controlled by a real PLC or the Com3Lab Course "Automation and Bus technology".

This package contains a class room license (25 users) with the following models:

- Motor control
- Traffic light control
- Liquid level control
- Service lift
- Stamping machine

728 872	Software: 5 Models CBS 9 (licence for 25 places)
---------	--

Available in German or Spanish

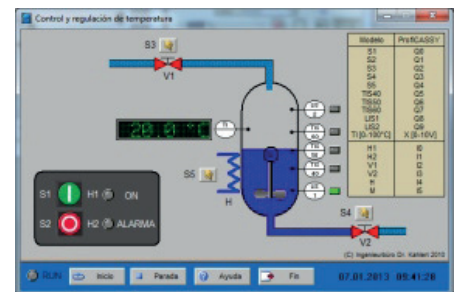

Profibus cable

- Standard Profibus cable, 2 wires, isolated
- Special design for quick mounting

730 4312	Profibus cable
----------	----------------

Bus connecting plug RS 485

- Connecting plug for Profibus until 12 MBIT/s 180° cable angle
- Terminating resistor with separating function, without PG plug

730 4313	Bus connecting plug RS 485
----------	----------------------------

Coupling 0.3

Rubber coupling sleeve for mechanical connection of two electrical machines of the 0.1 kW or 0.3 kW series.

731 06	Coupling 0.3
--------	--------------



Shaft end guard 0.3

Attachable guard for protection against contact with electrical machine rotating parts of the 0.1 kW or 0.3 kW series.

731 07	Shaft end guard 0.3
--------	---------------------



Coupling guard 0.3

Attachable guard for protection against contact with electrical machine rotating parts of the 0.1 kW or 0.3 kW series.

731 08	Coupling guard 0.3
--------	--------------------





Tacho generator 0.3

For registering the speed of electrical machines in the 0.1 kW and 0.3 kW series.

Technical Specifications:

- Output voltage: ± 1 V/1000 rpm

731 09	Tacho generator 0.3
--------	---------------------



Shunt wound machine 0.3

DC shunt wound machine for motor and generator operation. All windings are separately connected to 4 mm safety sockets.

Technical Specifications:

- Class: 0.3
- Power: 0.3 kW
- Voltage: 220 V
- Current: 1.8 A
- Excitation voltage: 220 V
- Excitation current: 0.25 A
- Speed: 2000 rpm
- International protection code: IP 20
- Insulation system: B/F

731 91	Shunt wound machine 0.3
--------	-------------------------



Squirrel cage motor 230/400/0.3

Three-phase asynchronous motor with squirrel cage rotor, industrial design with one shaft end.

Technical Specifications:

- Class: 0.3
- Power: 0.25 kW
- Voltage: 400 /230V, Y/ Δ
- Current: 0.76 /1.32 A
- Frequency: 50 Hz
- Power factor: 0.79
- Design: 4-pole
- Speed: 1350 rpm
- International protection code: IP 20
- Insulation system: F

732 104	Squirrel cage motor 230/400/0.3
---------	---------------------------------

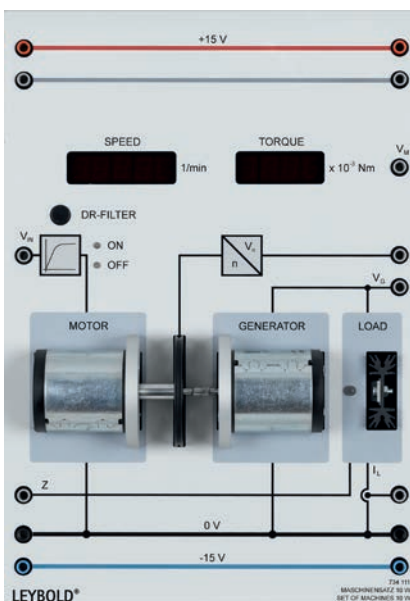

Set of machines 10 W

The set of 10 W machines is a technical controlled system for experiments on speed and voltage control. It consists of an electrical drive including digital speed sensing, a generator machine and an electronic load. Using the adjustable load, real generator operation can be investigated. The machine set makes it possible to measure the load characteristic of the generator and the dynamic behaviour of systems of higher order. A microprocessor controlled power module supplies the drive machine. Thus no external power amplifier is required. The set of machines comes with 7-segment displays for the measurement of speed and torque.

Technical Specifications:

- Speed: 3000 rpm max.
- Control voltage: ± 10 V
- Tachogenerator: ± 10 V
- Switchable prefilter, time constant $T = 800$ ms
- Power consumption: 10 W max.
- Generator efficiency: 40%
- Supply voltage: ± 15 V DC

734 111	Set of machines 10 W
---------	----------------------

Temperature Control System

For the investigation of continuous and discontinuous control loops.
Unipolar heat source (max. 20 W for 20 V) with temperature sensor, thermal protection switch, ventilator motor and „throttle flap“, built into a transparent air channel.

Controlled system output signal (controlled variable) switchable 2 mA/10 °C or 1 V/10 °C as desired.

Two possibilities for controlled system disturbance:

- via ventilator motor, internally with speed setter 1...10 or from an external signal source max. 20 V
- via „throttle flap“, position 0 (closed) up to position 4 (open)

Controlled system data:

- Temperature: max. 100 °C
- Delay time T_D : approx. 10 s
- Compensation time T_G : approx. 120 s
- Supply voltage: ± 15 V DC

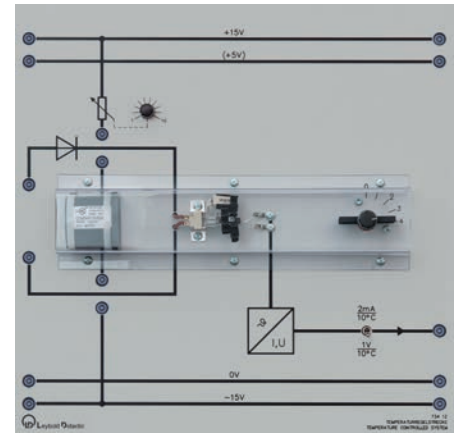

734 12 Temperature Control System

Gain and offset adjust

For the adjustment and matching of external signals to the normal voltage used in automatic control systems.

Technical Specifications:

- Input voltage range: -50 V...+50 V
- Level matching via adjustable gain: 0...1, 0...10, 0...100
- Smoothing of pulsating signals:
Time constants τ : 0.1...10 ms, 10...100 ms
- Offset voltage, switchable: -10 V...+10 V
- Coarse setting via rotary switch
- Fine setting via potentiometer
- Supply voltage: ± 15 V DC

734 19 Gain and offset adjust

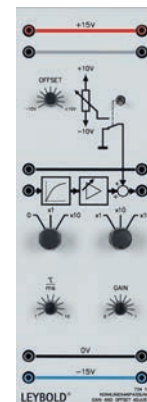

Actuator, 115...230 V/1 kW

For the connection of mains-operated DC motors 0.1 kW...1.0 kW. Electrical isolation between the control and the load side.

Technical Specifications:

- Signal voltage range (manipulated variable): 0...+10 V
- Output voltage of the thyristor half-bridge:
0... V_{mains} with a max. load of 1.0 kW
- Built-in automatic circuit-breaker (T 10 A) triggered thermally and for overcurrent
- Output voltage for excitation: $V_{DC} = f(V_{mains})$, max. 10 A
- Outputs: 4-mm safety sockets
- Mains connection for thyristor half-bridge: 115...230 V, 48...62 Hz
- Supply voltage: ± 15 V DC

Scope Of Delivery:

- Mains lead and earth-contact plug

734 22 Actuator, 115...230 V/1 kW

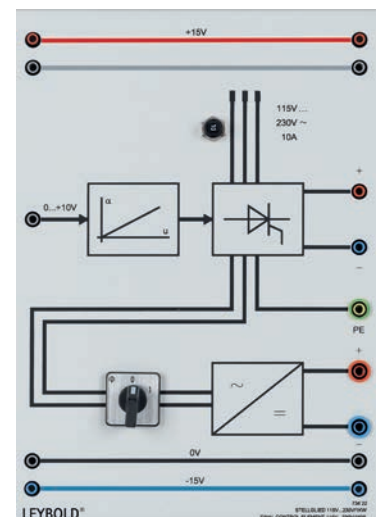

Connecting lead universal converter

25-pole sub-D connecting lead with two plugs, shielded, soft rubber and uncrossed design, length 2 m to connect the COM3LAB Power Electronics Board with the 3 x 230 V universal converter, cat. no 735 297.

For use in COM3LAB course PE II, cat. no. 700 22.

735 290 Connecting lead universal converter

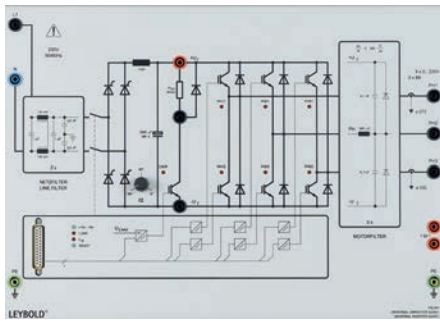

Universal converter 3 x 230 V

Transistor pulse converter with voltage link for the generation of a three-phase, frequency and amplitude-variable output voltage from an AC mains. This unit in conjunction with the corresponding control unit is used to assemble a frequency converter or servo amplifier.

Description:

- Single-phase mains connection
- Variable link voltage via fully controllable B2C rectifier bridge circuit
- Three-phase inverter built with IGBT (insulated gate bipolar transistor)
- Maximum operating frequency 20 kHz, resulting in good approximation of sinusoidal current as well as low noise build-up in the machine
- Output short-circuit proof, earth-fault proof and switch proof
- Interface for connection of the control unit (25-pole sub-D socket, TTL level)
- Each individual transistor can be switched on and off via the interface and is protected from damage with an interlocking device
- The respective activated IGBT's are displayed via LEDs
- Monitoring of the variable link voltage, machines and converter excess temperature, excess currents in the rectifier and inverter. Output of the switching status via interface and display via LEDs
- Integrated brake chopper
- Safe separated extra-low voltage (SELV) between the power component and the control unit
- Output currents are detected via Hall generators. Electrically separated output via interface
- 2 stage mains filter for the reduction of the line-bound interference
- 3-phase motor filter for the reduction of the edge steepness of the pulse voltages at the converter output to values $< 250 \text{ V}/\mu\text{s}$

Technical Specifications:

- Output voltage (V_{out}): 3 x 0...230 V
- Output current (I_{A}): max. 3 x 8 A
- Supply voltage: 200...240 V, 50/60 Hz via 4-mm safety sockets

Scope Of Delivery:

- 25-pole connecting cable

735 297	Universal converter 3 x 230 V
---------	-------------------------------



COM3LAB Course: Foundations of Local & Trunk Exchange Systems

The equipment set gives deep insight into the complete telephone and exchange technology in local and trunk exchange systems. Emphasis is laid upon the digital principles of TST switching networks, the implementation of service features and the voice signal coding.

Technical Specifications:

- Calling number display: 7-segment, 4 digits
- PC connection: USB

Scope Of Delivery:

- 4 switchboard modules
- 4 telephones same as RJ12
- 4 USB cable
- 1 CBT prospectus (LETS)
- 1 case

735 800	COM3LAB Course: Foundations of Local & Trunk Exchange Systems
---------	---

Additionally required:

Count	Cat.No	Name
1		PC with Windows XP/Vista/7/8

Additionally required:

- 1 PC with (at least) 4 USB connections, 1GHz, Pentium
- 1 monitor
- (1) printer

The COM3LAB course 735 800 fundamentals of the local and toll exchange requires no Master Unit (700 00USB). The course hardware is directly connected to the PC.

PAM Modulator

Pulse amplitude modulation (PAM) is achieved by sampling an analog signal. It serves as a preliminary stage for generating PCM signals. The sampling procedure itself supplies PAM of the first type (natural PAM). A sample&hold stage is required additionally for generating PAM of the second type. The training panel contains all the units required for setting up a 2-channel time-MUX system:

- 2 x anti-aliasing filters
- 2 x samplers
- 2 x s&H stages
- 1 x multiplex control

A variable duty cycle and a freely selectable sampling frequency allow practical measurements of pulse sequences. Verification of the sampling theorem after Shannon including a display of oversampling and undersampling. Investigation of multiplex control in 2-channel mode is possible.

Technical Specifications:

- Cut-off-frequency of the low-pass filters: 3,4 kHz
- Sampling frequency: 1 kHz...10 kHz
- Duty cycle: 0,1...0,9
- Input voltage: -10 V...+ 10 V
- Outputs: PAM1, PAM2, clock generator
- Supply voltage: +/- 15 V DC

736 061 PAM Modulator

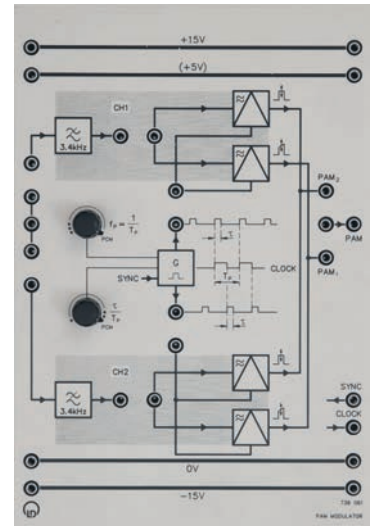

PAM Demodulator

Due to their spectral characteristics, PAM signals are demodulated with low-pass filters. The duty cycle is often increased in a series-connected sample&hold stage.

The training panel contains all the receiving components required for setting up a 2-channel time-MUX system:

- 2 x low-pass demodulators
- 1 x S&H stage
- 1 x Demultiplex control

A connectable speaker is integrated to allow an acoustic examination of the effects of sampling.

Technical Specifications:

- Cut-off frequency of the low-pass filters: 3.4 kHz
- Duty cycle: 0.1...0.9
- Input voltage: -10 V...+10 V
- Outputs: Channel 1, channel 2, clock generator
- Supply voltage: ± 15 V DC

736 071 PAM Demodulator

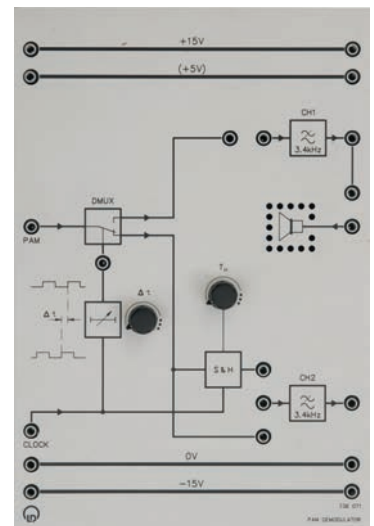

PCM Modulator

The sampled, discrete-time signal is quantized and coded in the PCM modulator. A fully digital (discrete time and value) signal is generated from the analog input signal of the PAM modulator. The PCM modulator allows an investigation of linear and nonlinear quantizing. The training panel also allows an investigation of DPCM (difference pulse code modulation) signals.

The device contains:

- 8-bit A/D converters
- LEDs for simultaneous display of all active bits
- Parallel/serial converters
- 13-segment compressor
- Predictor
- Clock control
- DC voltage source for coding experiments

Technical Specifications:

- Resolution: max. 8 bits, each bit can be deactivated individually
- Prediction (DPCM): previous sample prediction
- DC voltage source: -10 V...+10 V, with 10-turn potentiometer
- Input voltage: -10 V...+10 V
- Output: TTL level
- Supply voltage: ±15 V DC

736 101 PCM Modulator

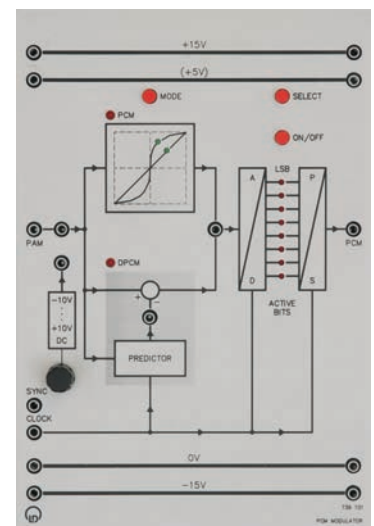

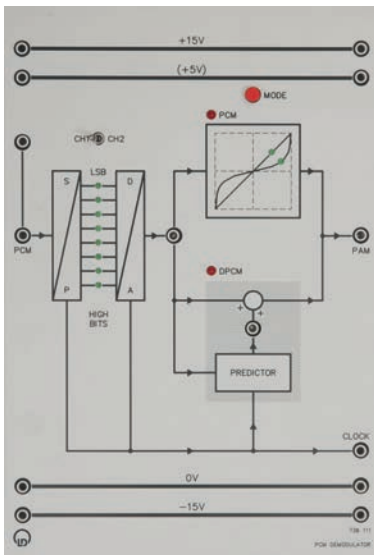

PCM Demodulator

The PCM demodulator receives the transmitted data and the clock signal serially via a common data line (transmission channel) from the PCM modulator. The PCM demodulator converts the received data back into a PAM signal. Experiments on companding can be performed together with the compressor of the PCM modulator. The training panel also allows the demodulation of DPCM signals.

The device contains:

- Serial/parallel converters
- LEDs for simultaneous display of the bits set high
- 13-segment expander
- D/A converter
- Predictor

Technical Specifications:

- Prediction (DPCM): previous sample predictions
- Input voltage: TTL level
- Output: $-10\text{ V} \dots +10\text{ V}$
- Supply voltage: $\pm 15\text{ V DC}$

736 111	PCM Demodulator
---------	-----------------



Gunn oscillator

The Gunn oscillator serves to generate microwave power. It has a modular design and can be broken down into the following components:

- Gunn diode module, length approx. 27 mm
- Rear housing wall
- Diaphragm with aperture, 8 mm diameter
- Waveguide adapter, 32 mm

Aluminium Gunn-diode module, Waveguide adapter with LD quick connectors.

Technical Specifications:

- Operating voltage: $8 \dots 10\text{ V DC}$
- Current consumption: approx. 120 mA
- Operating frequency: 9.40 GHz
- Microwave power: $> 10\text{ mW}$, typically 15 mW
- Connection: BNC socket
- Waveguide type: R100

737 01	Gunn oscillator
--------	-----------------

Gunn Power Supply with SWR Meter

The Gunn power supply delivers the DC and control voltages required for the operation of the Gunn oscillator and PIN modulator and enables the demodulated microwave signal to be quantitatively evaluated. Furthermore, this unit has various inputs and outputs for experiments on modulation and characteristics.

Design: 19" table-top unit with stand.

Technical Specifications:

Gunn Power Supply

- Gunn voltage: $-10\text{ V} < U_G < 0\text{ V}$ adjustable via 10-turn potentiometer, short-circuit proof
- Gunn current: max. 200 mA
- Display: $0 \dots 10\text{ V}$, $0 \dots 200\text{ mA}$, LED display for selected scale
- Movement: class 1.5 with mirror scale
- Outputs/inputs:
 - GUNN: DC supply of the Gunn oscillator
 - X/Y: for recording characteristics using an XY recorder
 - DOPPLER OUT: for experiments with Doppler radar
 - MOD IN: for direct modulation of the Gunn oscillator, input signal max. $\pm 10\text{ V}$



PIN Modulator

- Clock oscillator: 976 Hz, 0...5 V, 0...10 mA, short-circuit proof
- Outputs/inputs:
 - PIN: toggle switch position determines internal modulation through the clock oscillator or for external modulation
 - MOD: for external modulation of the PIN modulator, input signal max ± 10 V

Homodyne SWR Meter

- Principle: Lock-in detection with internal synchronization through the clock oscillator
- Dynamic range: 0...55 dB can be set in 12 steps, additional 5 dB available via variable gain
- Sensitivity: $1 \mu\text{V}_{\text{rms}}$ for full scale deflection
- Accuracy: ± 0.3 dB over the whole range
- Mid-frequency: 976 Hz
- Bandwidth: 10 Hz
- Display:
 - Power scale: + 0.5 dB...- 20 dB (calibrated in dB for square-law detectors)
 - SWR scale: 1.00...5
 - Linear scale: 0...100 % (0 dB corresponds to 100 %)
 - Movement: class 1.5 with mirror scale
- Inputs/outputs:
 - INPUT: unbiased, impedance 10 k Ω
 - AMP. OUT: DC output for the measurement voltage

Mod

- Inputs/outputs:
 - Input: jointly for ANALOG and TTL, impedance 50 Ω
 - Analog Out: analog signal max. ± 2 V, bandwidth 1 MHz, gain approx. 30
 - TTL Out: TTL level
 - All in-/outputs are connected with BNC sockets
- Mains connect.: 115/230 V, 50 Hz, approx. 20 VA with mains connection cable and earthing-pin plug
- Dimensions: 500 x 330 x 150 mm (L x W x H)
- Weight: approx. 8 kg

737 021 | Gunn Power Supply with SWR Meter

PIN Modulator

The microwave signal is amplitude-modulated using the PIN modulator. When limited to a modulation frequency, detection can be carried out in very narrow bandwidths. The effects of noise and interference remain small, the sensitivity of the measurements is improved. The PIN modulator can be used in the linear characteristic range as an analog amplitude modulator and in switching mode for digital modulation.

Design:
Aluminium module with LD quick connectors.

Technical Specifications:

For $f_0 = 9.40$ GHz:

- Insertion loss a_i : approx. 1 dB
- Back reflection loss a_R : approx. 15 dB
- Operation voltage: 0...1.0 V DC
- Current consumption: 0...10 mA
- Modulation frequency: > 5 MHz
- Connection: BNC socket
- Waveguide type: R100

737 05 | PIN Modulator

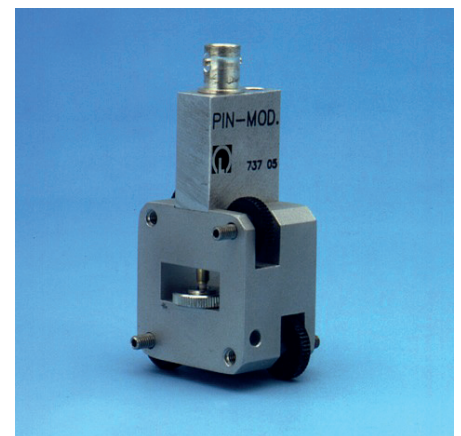



Unidirectional Line

The isolator (unidirectional line) is one of the nonreciprocal microwave components. Whereas a microwave travelling in the forward direction is subject to practically no attenuation, a wave travelling in the reverse direction is strongly absorbed. This component functions according to the field displacement law and is preferred for the decoupling of the oscillator from the rest of the measurement circuit.

Design: Waveguide built of aluminium.

Technical Specifications:

At $f_0 = 9.40$ GHz

- Isolation: > 20 dB
- Insertion loss: < 1.5 dB
- SWR: < 1.25
- Waveguide type: R100
- Length: 13 mm
- Weight: 50 g

737 06	Unidirectional Line
--------	---------------------



Waveguide Detector

The waveguide detector is used for detecting and mixing microwave energy.

Design:

Aluminium module with LD quick connectors. With short-circuit plate and 2 screws.

Technical Specifications:

- Connection: BNC socket
- Waveguide type: R100

737 08	Waveguide Detector
--------	--------------------



3-Screw Transformer

The 3-screw transformer is used to reduce mismatching, e.g. when matching horn antennas or other loads. It is also important for the generation of arbitrary reflections. As reactive elements the screws carry out the desired impedance transformation. The arrangement of the probes is slightly asymmetrical with respect to the flange planes. This enables better tuning in individual cases.

Design:

Aluminium module with LD quick-release connectors.

On the wide side of a rectangular waveguide there are 3 screws arranged along the centre line at a distance of $3/8 * \text{LAMBDA}$. The screws act as probes and can be screwed completely into the waveguide. There is an insert nut provided in the base section for mounting a support.

Technical Specifications:

- Frequency range: 8.2 GHz...12.4 GHz
- Waveguide type: R100
- Length: 45 mm
- Weight: 150 g

737 135	3-Screw Transformer
---------	---------------------



Small Horn Antenna

Horn antenna used as feeding radiator for dish antennas, and for antenna gain measurements.

Design:

- Aluminium, red lacquer finish
- Dimensions (WxHxL): 54x31x39 (mm)
- Frequency range: 8 GHz...12 GHz
- Gain: 10 dB at 10 GHz
- Waveguide type: R100
- Incl. two thumb screws M4

737 20	Small Horn Antenna
--------	--------------------

Large horn antenna

Horn antenna use as feeding radiator for dish antennas, and for antenna gain measurements.

Technical Specifications:

- Frequency range: 8 GHz ... 12 GHz
- Gain: 15 dB at 10 GHz
- Waveguide type: R 100

737 21 Large horn antenna



Set of Microwave Absorbers

When conducting experiments in free space, especially when recording directional diagrams in antenna technology, a reflection-free measurement area is indispensable. With the aid of the absorbers an effectively anechoic chamber can be set-up with very little effort due to the small free space wavelength in the microwave range.

Consisting of:

- 6 absorbers approx. 500 x 500 x 60 (mm)
- 3 of them mounted on metal stands

737 390 Set of Microwave Absorbers

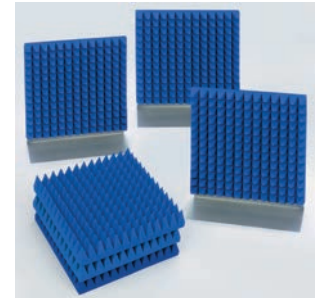

Dish Antenna

The quasi-optical properties of microwaves permit effective beam focusing using reflector antennas. The main reflector of the parabolic antenna can be fed by various primary radiators, e.g. horn antenna, dipoles or yagi antennas. The dish antenna is used in experiments with the rotating antenna platform (737 405) and in microwave radio links (T 7.4.8). Primary radiators are not contained in the equipment set.

Consisting of:

- 1 main reflector, diameter 400 mm, $f/D = 0.4$
- 1 holder for main reflector with stand for primary radiator
- 1 stand rod 245 mm, M6
- 1 thumb screw M5x40
- 2 thumb screw M6x17

737 452 Dish Antenna



COM3LAB Course: Microwave Technology I

The COM3LAB Course Microwave Technology I gives an introduction into vector analysis. Additionally measurements using the measuring line are carried out. Devices under test are passive UHF circuits in microstrip- and SMD technology.

Topics:

- Display formats for network analysers, Smith chart and Bode plot
- Reference measurements and SOLT calibration
- Pi filters
- Stubs as reactive elements
- Return loss of resistive terminations
- Frequency response of reflection-free termination and mismatch
- The $\lambda/4$ stub and the $\lambda/4$ transformer
- Matching with open end parallel stub
- Line resonators
- Equivalent circuits and simulation with microwave CAD
- Standing wave effect for different line terminations
- Assessing wavelength through open/short comparison
- Shifting the standing wave by elongation of the line
- Measuring wavelength for different frequencies
- Phase trend in a standing wave
- Wilkinson dividers and resistive dividers
- Insertion loss of power dividers
- Insertion/coupling loss and isolation of the rat race coupler
- Directional coupler investigations (main branch/auxiliary branch)

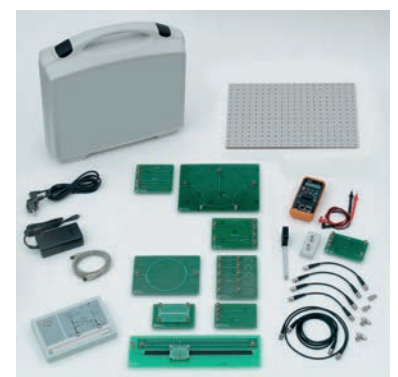

Virtual laboratory:

- Network analyser
- Bode diagram
- Smith chart

Additional functions:

- Word processing
- Printer
- Pocket calculator
- Free experimentation
- Glossary

Technical Specifications:

- Network analyser
 Frequency range: 260 MHz ... 520 MHz Frequency resolution: 10 kHz ... 10 MHz
 Phase resolution: 1°
 Output power: Port 1 approx. +3 dBm (2 mW) Input power: Port 2 max. +17 dBm
 Dynamics: S11 > 25 dB, S21 > 50 dB
 Operating modes: Sweep / CW / Stationary waves / HF circuit
 Evaluations: average values, markers, zoom
 Presentation formats: Bode diagram with separate plots for quantity/phase in Cartesian coordinates. Quantity in lin/log presentation.
 Smith Chart, the circuit diagram with joint
 Display of quantity and phase. Tabular listing of the measured values. Display of complex reflection factor Γ and complex impedance Z.
 Supply voltages: +5 V, +/- 15 V
 Dimensions: 210 mm x 135 mm x 45 mm
 Mass: 400 g
 Power supply: 100-240 VAC, 50/60 Hz
- Attenuator and filter
- Resistive terminations
- Complex terminations
- UHF measuring line
- Power splitter
- Hybrid ring coupler
- Directional coupler
- Ring resonator
- Digital Hand measurement unit

Scope Of Delivery:

Count	Cat.No	Name
1	737 530	Network Analyser
1	737 531	Network Analysis Accessories
1	737 540	Attenuators & Filters
1	737 541	Resistive Terminations
1	737 542	Complex Terminations
1	737 543	UHF Measuring Line
1	737 544	Power Divider
1	737 545	Rat Race Coupler
1	737 546	Directional Coupler
1	737 547	Ring Resonator

- 1 x Mounting panel
- 1 x Case for storage
- 2 x BNC plugs, 50 Ohm
- 6 x HF cables
- 2 x BNC T adapters
- 1 x Multimeter
- 1 x Measuring tape

737 51	COM3LAB Course: Microwave Technology I
--------	--

Additionally required:

Count	Cat.No	Name
1		PC with Windows XP/Vista/7/8

COM3LAB Course: Microwave Technology II

Supplementary course to 737 51 COM3LAB Course Microwave Technology I. The equipment set gives insight into active microwave components and a ferrite element.

Topics:

- Determining the resonance of rod antennas
- Insertion loss and stop band attenuation of the circulator
- Circulator bandwidth
- Short-circuited parallel stubs
- Transformation behaviour of long lines
- Attenuation of coaxial lines
- Frequency dependency of line attenuation
- Calculation of dielectric constants from phase measurements
- Gain and return loss of an MMIC amplifier
- SPST and SPDT switches with PIN diodes
- PIN diode switching behaviour
- Microwave transmission links
- U/f and f/U converter characteristics
- Capture range of the superhet

Virtual lab:

- Network analyser
- Bode diagram
- Smith diagram

Additional functions:

- Word processing
- Printer
- Pocket calculator
- Free experimentation
- Glossary

Technical Specifications:

- 1 UHF aerials
- 1 3gate circulator
- 1 MMIC amplifier +10 dB
- 1 VCO
- 1 UHF Superhet receiver
- 1 HF circuit

Scope Of Delivery:

Count	Cat.No	Name
2	562 791	Plug-in power supply, 12 V AC
1	737 548	UHF Antennas
1	737 549	3 Port Circulator
1	737 550	MMIC Amplifier +10 dB
1	737 551	VCO
1	737 552	UHF Superhet Receiver
1	737 553	RF Switch

- 2 plug-in power supply units 230/12 VAC
- Telescopic aerials

737 52	COM3LAB Course: Microwave Technology II
--------	---

Additionally required:

Count	Cat.No	Name
1	737 51	COM3LAB Course: Microwave Technology I
1		PC with Windows XP/Vista/7/8





Network Analyser

For automatic testing and the PC based representation of vector S-Parameters of one and multiport devices.

- Frequency range: (250...500) MHz
- Incl. control- & evaluation software. With plug-in unit: 230 V / 12 V, 1600 mA, 50 Hz.
- PC necessary.

737 530 Network Analyser

Network Analysis Accessories

The accessories set comprises:

- 1x Mounting panel 737 5311
- 1x Calibration board 737 5312
- 1x Plug box NWA 524 079
- 2x BNC termination, 50 Ohm
- 4x Coax-cables, BNC male / male, L = 0,25 m
- 1x Coax-cables, BNC male / male, L = 1 m
- 1x Coax-cables, BNC male / male, L = 2 m
- 2x BNC-T connectors
- 1x Autorange Multimeter
- 1x Ruler

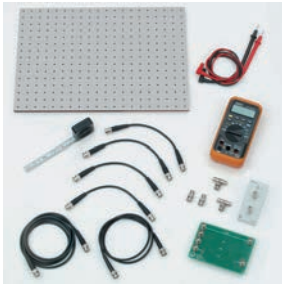

737 531 Network Analysis Accessories

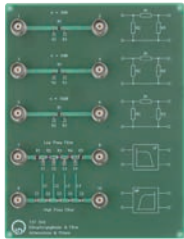

Attenuators & Filters

Unit containing fixed attenuators in pi configuration with 3/6/10 dB as well as a low pass filter and a high pass filter of higher order.

737 540 Attenuators & Filters



Resistive Terminations

For investigation of matching this unit contains different resistive loads (ohmic terminations) as well as lambda/4-stub and lambda/4-transformer.

737 541 Resistive Terminations

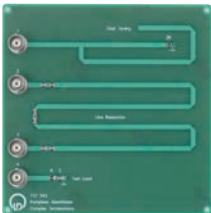

Complex Terminations

The unit contains an ohmic load (2R) matched by an open stub, a capacitive coupled line resonator (2 line sections) and a complex test load (RC).

737 542 Complex Terminations

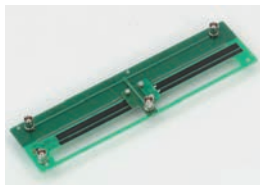

UHF Measuring Line

Measuring line with integrated displacement transducer for investigation of mismatching in the UHF range. Printed cm scale for step to step measurements. For operation the NWA Box of „Network Analysis Accessories“ (737 531) is required. Measuring range: 30 cm

737 543 UHF Measuring Line

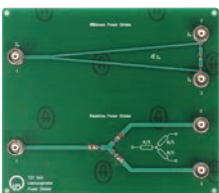

Power Divider

Power dividers are used to split incident RF power into several outputs and vice versa. The unit comprises 2 different splitters: a Wilkinson and a resistive power divider.

737 544 Power Divider

Rat Race Coupler

Device used for decoupling of UHF components. Includes ground plane for telescope antenna.

737 545	Rat Race Coupler
---------	------------------

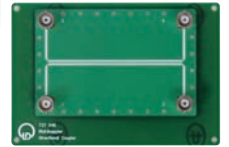

Directional Coupler

Device used for the separation of outgoing and reflected waves in reflectometers as well as probing RF power.

737 546	Directional Coupler
---------	---------------------

Ring Resonator

Resonator in form of a closed microstrip loop.

737 547	Ring Resonator
---------	----------------

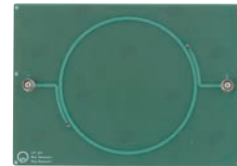

UHF Antennas

Set of UHF antennas comprising a telescopic antenna with BNC plug and a telescopic antenna with 4mm plug. Operating frequency: 200 MHz -500 MHz.

737 548	UHF Antennas
---------	--------------

3 Port Circulator

Circulators are nonreciprocal components. Their function is ruled by anisotropic properties of ferrite materials. Circulators are used for decoupling microwave loads and sources.

737 549	3 Port Circulator
---------	-------------------

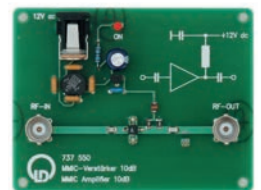

MMIC Amplifier +10 dB

UHF-amplifier for use in UHF- and microstrip circuits. Gain:+10 dB
Max. output power: 50 mW

737 550	MMIC Amplifier +10 dB
---------	-----------------------



VCO

UHF Oscillator with modulation input (VCO) and V/f converter used for the transmission of measuring voltages. Centre frequency: 433.92 MHz
Power: > 5 dBm

737 551	VCO
---------	-----

UHF Superhet Receiver

UHF Superhet Receiver used for reception of signals from 737551 VCO. Input frequency: 433.92 MHz

737 552	UHF Superhet Receiver
---------	-----------------------

RF Switch

With PIN diodes in serial and parallel configuration it is possible to realise different types of switches (SPST and SPDT). Insertion - and isolation losses are compared as function of the control current.

737 553	RF Switch
---------	-----------

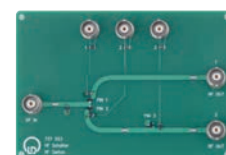



COM3LAB Course: Radar Technology I

The course COM3LAB Radar Technology I works with a mono-static ultrasonic radar.

Topics:

- Distance measurement
- Echo representation
- Delay measurements
- Scattering areas
- Tracking,
- Target suppression
- Representation of mobile targets
- Detection of noncooperative / cooperative targets and stealth.

The system works with a PC-controlled base station with current Bluetooth Wireless data transfer.

Virtual lab:

- Binary close echo attenuation (STC) with close / far range
- Discriminator fire control radar with optical / acoustic lost / found detector

The hardware is connected to the PC via Bluetooth. Course content, experiment instructions and tasks are taught via a course-specific software.

Technical Specifications:

- **Principle**
Monostatic ultrasonic pulse sonar
- **Radar type**
Incoherent radar on multiprocessor basis,
Carrier frequency: 40 kHz, ADC sampling rate: 20 kHz,
Range > 10 m, Distance resolution < 1 cm,
Data transmission: Bluetooth
Transmitter pulse power: 120 dB SPL
Receiver echo resolution: max. 500 measuring points Echo quantisation: 17 Bit
Duplexer: PC-controlled
Gate generator: Pulse control factor 1 % Number of carrier fluctuations adjustable: $n = 1...32$
Logarithmic amplifying dynamic: > 100 dB
- **Radar aerial**
Parabol, 400 mm, 29 dB, Aerial resolver with angle resolution: $0.5^\circ/1^\circ/2^\circ$
- **Display mode / display units**
Radar image processor with binary target extractor
A scope: Logarithmic 0...-100dB
Linear 100% ...0,001%
PPI:
Classic with decision threshold
Digital: colour-coded echo amplitude measurement
PPI plot with offset display and echo zoom PPI display: monochrome, colour
- **Primary radar (PR)**
Operating modes: Tracking, Scanning (Sector Scan, Full Scan), manual positioning
- **Secondary radar (SSR)**
Transponder with automatic switch-off delay (15 min) Operating modes: Radar beacon, Friend/foe recognition (IFF). Editable transponder list with flight data simulator for flight height, direction, speed
- **Collision prevention:**
TCAS with two-zone monitor tracking

Scope Of Delivery:

- 1 Sonar Base 737 605
- 1 Sonar Pulse Generator 737 606
- 1 Set passive targets 737 610
- 2 Transponders 737 620
- 2 Camera tripods 300 59
- 2 Storage trays 240x460x80 mm
- 5 Partitions ZW 24
- Incl. power supply, battery charger, cable, accessories and multimedia CBT program.

737 60	COM3LAB Course: Radar Technology I
--------	------------------------------------

Passive targets, set

Passive reflectors, scatterers and absorbers of different geometrical form and radar cross section for investigations in radar and antenna systems.

The equipment includes:

- 1 x corner reflector, edge length approx. 180 mm
- 1 x square reflector approx. 200x200
- 1 x spherical reflector (segment) diameter approx. 370 mm
- 1 x absorber record 500x500x100
- 1 x plastic bag, DIN A4
- 2 x holder for reflectors
- 1 x pencil with record
- 1 x stand rod 180 mm, M6
- 1 x stand rod 205 mm, M6
- 4 x knurled-head screw M4
- 1 x knurled-head screw M5
- 1 x knurled-head screw M6

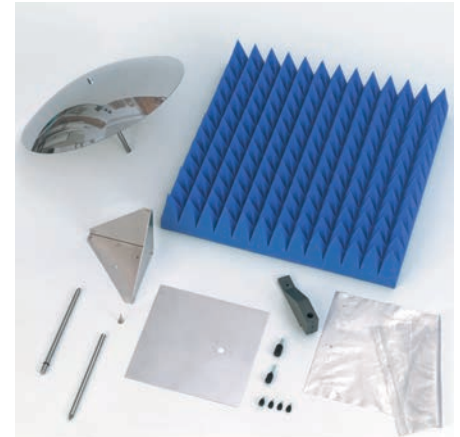

737 610 Passive targets, set

Doppler Converter

For the supply of the Doppler module. The Doppler module (radar transmitter / receiver) consists of the Gunn Oscillator 737 01 with horn antenna. The Doppler converter generates a Doppler signal by mixing the transmitter's output signal with the backscattered echo from the target. The Doppler signal is filtered and downconverted into the baseband. The analysis of the Doppler signal in the time- and frequency domain can be performed using the Sensor-CASSY. The Doppler converter is optimised for experiments with the track and trolley for low speeds typical in laboratory environments.

Contains:

- 1 x Doppler converter
- 4 x Stand rod 245 mm, M6

Technical Specifications:

- Supply voltage: 12 VAC
- Gunn supply: 8 V, 150 mA
- Doppler output: 5... 500 Hz



737 615 Doppler Converter

MTI simulator

The MTI simulator consists of a Doppler target and a target control. It allows the quantitative investigation of Doppler radar experiments with a stationary Doppler target. The Doppler target contains a metal membrane which is able to vibrate with a backscatter area of approx. 0.2m². The radar signals reflected by the Doppler target cover a frequency range corresponding to typical speeds of moving targets in laboratory experiments. Three speed ranges can be set:

- 0,8 cm/s ... 8 cm/s
- 8 cm/s ... 80 cm/s
- 80 cm/s ... 8 m/s

The target control includes fine adjusters for matching the frequency and the amplitude.

Target frequency: 5 Hz... 500 Hz
 Membrane amplitude: ca. 5 mm
 Radar cross section: 0,2 m² for f=9.40GHz
 Supply voltage: 12V AC

Dimensions:

Target control: 115mm x 115mm x 60mm
 Doppler target: diameter 150mm, length ca. 315mm

Mass:

Target control: ca. 300g
 Doppler target: ca. 1000g

Contains:

- 1x Doppler target
- 1x Target control unit
- 1x Stand rod 215 mm, M6



737 630 MTI simulator



COM3LAB Course: Radar Technology II

The course COM3LAB Radar Technology II works with a X-band microwave source. It examines the principles and applications of the Doppler effect by measurements in the time- and frequency domain (FFT analysis of the Doppler spectrum in the base tape).

Topics:

- Approach detector (Intrusion Detection)
- Speedometer
- Door opener
- Damping of electromagnetic waves

Technical Specifications:

- 1 Gunn oscillator
- 1 Large horn aerial
- 1 Set of passive targets
- 1 Doppler converter
- 1 MTI simulator
- 1 Set of nep absorbers

Scope Of Delivery:

Count	Cat.No	Name
2	562 791	Plug-in power supply, 12 V AC
2	648 07	Storage tray S24-FN
5	648 08	Partition ZW 24
1	737 01	Gunn oscillator
1	737 21	Large horn antenna
1	737 390	Set of Microwave Absorbers
1	737 610	Passive targets, set
1	737 615	Doppler Converter
1	737 630	MTI simulator

- 2 Plug-in power supply units 230 V / 12 V AC
- 2 storage trays (240x460x80) mm
- 5 partitions ZW 24

737 65	COM3LAB Course: Radar Technology II
--------	-------------------------------------

additionally required:

Count	Cat.No	Name
1		PC with Windows XP/Vista/7/8

LIT: E2.2.2.0 DC Machines 0.3 (German)

775 190DE	LIT: E2.2.2.0 DC Machines 0.3 (German)
-----------	--



COM3LAB

INDEX

IN ALPHABETICAL ORDER

On the following pages you will find the index for our equipment sets and individual components.

1-3

3 Port Circulator 109
 3-Screw Transformer..... 104

A

3 Port Circulator 109
 3-Screw Transformer..... 104
 AC Technology I21, 63
 AC Technology II.....21, 64
 Actuator 38, 41, 99
 Attenuators and Filters..... 108
 Automation and Bus Technology..... 27-28, 39, 74
 Automation Technology39
 Automotive Data Buses..... 47, 82
 Automotive Digital Technology II..... 46, 84
 Automotive Technology I 44, 80

B

Bridging Plugs.....56
 Bus Connecting Plug..... 39, 97
 Bus Systems.....47

C

Circuit Design.....36
 COM3LAB Carrier Standard.....60
 COM3LAB Master Unit20-41, 44-47, 50, 59

COM3LAB Protoboard II 36, 95
 COM3LAB Software.....58
 COM3LAB TT: Amplifier Circuits36
 COM3LAB TT: Power Supply Circuits36
 COM3LAB Vehicle Sensors.....45, 81
 Communication Technology.....31
 Communications Networks32
 Complex Terminations 108
 Compressor Connection Hosing.....27
 Connecting Lead Universal Converter 40, 99
 Control of Didactical Lines.....37
 Control of Industrial Lines.....38
 Control Technology I28, 37-38, 41, 91
 Control Technology II..... 28, 37-38, 41, 92
 Coupling 38, 41, 97

D

DC Technology I.....20, 61
 DC Technology II..... 20, 62
 Digital and Bus Technology.....46
 Digital Communication Technology.....31, 87
 Digital Liquid Control System.....37
 Digital Technology I..... 23, 46, 67
 Digital Technology II 23, 46, 68
 Digital Temperature Controlled System.....37

Directional Coupler.....	109	M	
Dish Antenna.....	105	Machines	37, 98
Doppler Converter.....	111	Measurement Technology.....	26
Drive Technology	29, 41	Measuring, Control, Automation.....	28
E		Mechatronics.....	27
Electina Design Suite, COM3LAB Support	36, 94	Microcontroller I	35, 77
Electina Standard, COM3LAB Support.....	36, 94	Microcontroller II	35, 78
Electrical Components	22	Microwave Absorbers.....	105
Electrical Machines I.....	29-30, 41, 73	Microwave Technology I	34, 106
Electrics	44	Microwave Technology II	34, 107
Electronic Components I.....	22, 65	MMIC Amplifier.....	109
Electronic Components II.....	22, 66	Modem Technology	31-32, 88
Electropneumatics	27, 75	Motors and Generators	30
F		MTI Simulator.....	111
Foundations of Local & Trunk Exchange Systems.....	100	N	
G		Network Analyser.....	108
Gain and Offset Adjust.....	38, 41, 99	O	
Gunn Oscillator.....	102	Operational Amplifier	24, 28, 90
Gunn Power Supply with SWR Meter	103	P	
L		PAM Demodulator.....	101
Large Horn Antenna	105	PAM Modulator	101
Low Noise Compressor	27	Panel Frame SL85.....	40-41, 96
		Panel Frame T130.....	37-38, 96

Passive Targets.....	111	S	
PCM Demodulator.....	102	Safety Cable.....	20-41, 44-47, 50, 60
PCM Modulator.....	101	Safety Connecting Lead.....	37-38, 40-41, 52-55
Photovoltaics.....	50, 79	Sensor Technology.....	26, 28, 93
PIN Modulator.....	103	Sensors.....	45
Pneumatics Board.....	27, 76	Shaft End Guard.....	38, 40-41, 97
Power Divider.....	108	Shunt Wound Machine.....	38, 41, 98
Power Electronics I.....	29, 40, 69	Single-Phase Supply Unit.....	40, 96
Power Electronics II.....	29, 40, 70	Small Horn Antenna.....	104
Profibus Cable.....	39, 97	Squirrel Cage Motor.....	40, 98
Profi-CASSY Starter 2.....	39, 57	Stabilised Power Supply.....	37-38, 41, 96
 R		 T	
Radar Technology I.....	33-34, 110	Tacho Generator.....	38, 41, 98
Radar Technology II.....	33-34, 112	Telecommunication Lines.....	31-32, 89
Radiolocation.....	33	Temperature Control System.....	99
Rat Race Coupler.....	109	Three-Phase Technology.....	25, 29-30, 71
Reception Technology RX433.....	31, 86	Transmission Technology TX433.....	31, 85
Resistive Terminations.....	108	Trunk Exchange Systems.....	32
RF Switch.....	109	 U	
RF Technology.....	34	UHF Antennas.....	109
Ring Resonator.....	109	UHF Measuring Line.....	108

UHF Superhet Receiver..... 109
Unidirectional Line..... 104
Universal Converter 40, 100

V

VCO 109
Vehicle Fundamentals Digital & Bus Technology.....83

W

Waveguide Detector..... 104

TECHNICAL SERVICE AND CONSULTING

LEYBOLD DOES NOT ONLY PROVIDE THE HIGHEST POSSIBLE PRODUCT QUALITY, BUT ALSO INDIVIDUAL ADVICE AND TECHNICAL AFTER-SALES SERVICE.

INDIVIDUAL ADVICE AND STOCK-TAKING

Are you planning to re-equip your laboratory or simply to add to its equipment? Our specialised advisor will be happy to give you support by suggesting a tailor-made combination suitable to your type of school.

GOODS SERVICE, INSTALLATION COMMISSIONING AND ON-SITE BRIEFING

We would be delighted to check your new equipment on site for completeness and functionality. We can either take on the whole task of installation for you or our specialists can commission the devices and systems that you have already installed on site yourselves. We would, of course, be delighted to conduct one or more tests together with you and to explain in detail the functions of each individual device.

LEYBOLD®

TECHNICAL AFTER-SALES SERVICE

You may have a technical question on one of our devices or pieces of equipment. Our service team is available by telephone at +49 2233 604-430 and by e-mail at service@ld-didactic.de.

SPARE PARTS SERVICE

You can naturally order replacement parts for your equipment.

REPAIR SERVICE

If, despite our demanding quality standards, you should find a fault in your LEYBOLD product, we will naturally repair it as soon as possible. If you still cannot make the equipment work as intended after calling our technical service, you can find help quickly and easily through our „on-site service“. Our service technicians come to you, to find the appropriate technical solution on site. Alternatively, you can of course also send your device for repair by post.

REPAIR GUARANTEE FOR A MINIMUM OF 10 YEARS

Our products stand for high quality and durability. If your device should become faulty even many years after purchase, generally we will still be able to repair it. We guarantee the repair of all our devices for 10 years from the date of purchase – and for much of our products, for much longer.



INDIVIDUAL
ADVICE
ON-SITE

TECHNICAL
SERVICE
AFTER-SALES

BRIEFING
ON-SITE



GENERAL TERMS AND CONDITIONS OF SALE

as of: 09.01.2012

1. General

- 1.1 The following terms of sale apply exclusively for all deliveries, services and offers made by LD Didactic GmbH (hereinafter: LD) with respect to entrepreneurs, legal entities under public law or public separate assets (hereinafter: buyer). An entrepreneur is any natural or legal person exercising his/her commercial or independent occupational interests by concluding a legal transaction. Buyer conditions which are contrary to, or deviate from, these terms of sale are only recognized if they have been given express consent. The buyer's general terms of business shall also not be deemed applicable even though these General Terms and Conditions provide no applicable stipulation, are incomplete or ineffective.
- 1.2 These terms and conditions of sale shall also apply to all future business with the buyer to the extent they represent legal transactions of a related nature, even then when they have not again been expressly agreed.

2. Offer and acceptance period

- 2.1 Offers made by LD are subject to change and non-binding. An agreement between LD and the buyer materializes only then when LD accepts the buyer's order.
- 2.2 LD reserves the right to accept buyer orders within a period of three weeks after receipt of the buyer's order. With acceptance of the offer a binding contract is concluded.

3. Scope of performance

- 3.1 The quality as stated in the order confirmation (performance specification) is completely and finally determinant for the characteristics of the subject of delivery. In particular, the general public statements made by LD or the statements made by a supplier, his vicarious agents or any third party do not represent any supplementary or modifying description of the delivery subject.
- 3.2 Details contained in catalogues, brochures and quotation documents are non-binding to the extent they are not explicitly designated as binding.
- 3.3 In individual cases LD is entitled to structural modifications and the use of different materials when these measures are not adverse to any buyer interests meriting protection.
- 3.4 LD retains the property and proprietary rights to all documents furnished in conjunction with the buyer's order; such as calculations, drawings and so forth. These documents may not be made available to third parties without the written consent of LD.
- 3.5 Upon request, all documents which were furnished by LD shall be returned without delay. It shall not be necessary to request the return of such documents in the event the order is not issued to LD or LD declines order confirmation.

4. Pricing and terms of delivery

- 4.1 Prices shall be understood to be ex-works (INCOTERMS 2000). Installation and commissioning as well as additional deliveries and services will be additionally charged at cost price.
- 4.2 For orders delivered within Germany, shipping charges will be waived if the order amount equals or exceeds €150. For orders delivered within Germany amounting to less than €150, a flat rate of €15 net for shipping and handling will apply.
- 4.3 It should be noted that for foreign orders (i.e. outside Germany), the shipment to foreign delivery addresses and bank transfers for payment may result in additional taxes or costs which are not collected by LD or placed in the invoice.
- 4.4 LD shall additionally charge transaction taxes (turnover tax, etc.) in accordance with the given effective legal regulations.
- 4.5 Notwithstanding an express agreement to the contrary, LD shall, at the buyer's expense, insure ordered goods against the standard transport risks, including damage by breakage. Insofar as assembly, assembly supervision or commissioning is to be performed, the relevant LD terms and conditions shall apply additionally.

5. Transfer of risk

- 5.1 Upon contractual delivery, the risk of accidental deterioration or accidental destruction shall pass to the buyer.
- 5.2 In the event of a sale to destination according to buyer's instructions, the risk of accidental loss or deterioration shall pass to the buyer along with transfer to the person responsible for transport but not later than departure of the goods from the plant/warehouse. This also applies in the case of partial deliveries and when LD has assumed responsibility for other services.
- 5.3 If shipping is delayed due to circumstances for which LD is not responsible, the risk shall pass to the buyer when he is notified the delivery is ready for shipment.

6. Terms of delivery

- 6.1 Delivery dates or periods can be agreed in writing as binding or non-binding. Disregard for the written form has no influence on the effectiveness of the agreement. LD may exceed non-binding delivery periods by up to six weeks. LD is only in delay of performance after the six week grace period if a reminder is received from the buyer. If subsequent order changes are agreed then a new delivery date must also be agreed. Otherwise the delivery period shall be deemed extended for a reasonable amount of time.
- 6.2 The delivery period only begins after all commercial and technical prerequisites for executing the order have been clarified with the buyer, any documents to be procured by the buyer have been received by LD, any necessary permits and releases have been issued, and agreed advance payments have been credited to an LD bank account. The delivery deadline shall be deemed met when, up to its expiration – providing the buyer has fulfilled the above contractual obligations – the delivery item is turned over to the first carrier or the buyer has been advised the delivery is ready for shipment. Partial deliveries shall be admissible unless they are of no interest to the buyer. Delivered items, even when they exhibit minor defects, are to be accepted by the buyer; the delivery deadlines are thus deemed as met.

- 6.3 Delivery and performance delays due to Acts of God, natural catastrophes or because of blameless work conflicts, blameless transportation or business disturbances, blameless material defects, export permits not issued, and similar grounds at LD and/or its suppliers entitle LD to rescind the order completely or in part or to postpone the delivery deadline until the cause of delay has been alleviated – but not longer than two months – without recourse for the buyer against LD for neglect of duty. The buyer is entitled to withdraw from the order if the aforementioned grounds persist for longer than two months. The buyer remains free to exercise his legal rights of cancellation at an earlier point in time – for instance due to frustration of contract or blameless impossibility of performance on the part of LD.
- 7. Terms of payment**
- 7.1 The net invoice amount is payable, without any discount, immediately upon receipt of invoice unless another payment period has been explicitly agreed. Partial deliveries shall entitle LD to invoice the respective partial delivery.
- 7.2 If the order purchase price is over €20,000 the buyer shall make a down payment equal to 50 % of the purchase price. If the order purchase price is over €50,000 the buyer shall make full payment in advance.
- 7.3 The buyer is in default, without reminder, 14 days after the due date of LD entitlement and receipt of the invoice or delivery. In the event of default, LD is entitled, to demand interest at a rate of eight percentage points over the base interest rate of the European Central Bank. Proof of even higher damages incurred by LD is permissible anytime. The buyer is at liberty to prove the damages incurred by LD were lower.
- 7.4 Payments shall be effected exclusively to one of the appointed LD payment offices. They are to be effected on the date due on a postage- and expense-free basis without any deductions. Charges, expenses or other costs which may be incurred by LD in consequence of a separately agreed acceptance of bill of exchanges or checks shall be debited to the buyer. For payments of any kind, the day upon which LD is able to dispose over the amount in question shall be deemed the date of performance.
- 7.5 Offsetting balances and rights of lien may only be asserted with indisputable or legally established counterclaims.
- 7.6 LD is entitled to assign its claims against a buyer arising from a contract relationship in advance and/or subsequently, in particular for financing purposes.
- 8. Retention of title**
- 8.1 Delivered items remain the property of LD until such time as all liabilities arising from the business relationship, including future or conditional claims, have been settled in full. In the event the buyer defaults on payment, LD is entitled to repossess the delivery item at issue (hereinafter: conditional commodity) without issuing a payment reminder demand. Insofar as the validity of retention of title is subject to mandatory special or legal prerequisites, the buyer shall ensure they are fulfilled.
- 8.2 To the extent he is not in default, the buyer shall be entitled dispose over the delivery item in the ordinary course of business. Claims which accrue to the buyer during the period of retention of title on the basis of resale or other legal grounds (including all balance receivables in current accounts) shall irrevocably be ceded in full amount to LD in advance as a form of security. Subject to revocation by LD, the buyer is empowered to collect such claims on a trust basis.
- 8.3 At the request of the buyer, LD shall undertake to release securities to which it is entitled, provided the value of such securities exceeds the unsettled claims to be secured by more than ten one-hundredths.
- 8.4 The buyer shall process and treat the delivery item on behalf of LD without giving rise to any obligation on the part of LD. If the delivery item is treated or combined, mixed or blended with objects which do not belong to LD (§§ 947 et seq. German Civil Code), LD shall be entitled to a co-ownership share in the new object at the ratio of the value of the delivery item to the other processed goods at the point in time before they were treated, combined mixed or blended. If the buyer acquires sole ownership pursuant to law, he hereby grants LD an appropriate co-ownership share or preserves the object for LD to this end. The provisions contained in item 8 also apply respectively to such co-ownership share.
- 8.5 The buyer shall immediately inform LD about any levy of distress or third party seizures with respect to the conditional commodities.
- 8.6 During retention of title, the buyer is obliged to adequately insure the delivery item at his own expense against theft, breakage, fire and water damage and, at the request of LD, furnish evidence to this effect. In the requested evidence is not presented within a reasonable period, LD shall be entitled to insure the delivered item at the expense of the buyer.
- 9. Warranty**
- 9.1 For defects in the delivery item detected prior to the transfer of risk, LD is, at its own option, entitled to either rectify such defects or make a replacement delivery (supplementary performance). The buyer shall bear the cost of return shipment for the defective item insofar as this cost is not disproportionate to the value of the item.
- 9.2 If supplementary performance proves to be unsuccessful, the buyer is entitled to request cancellation of sale or reduction of purchase price without prejudice to potential damage compensation claims. Supplementary performance is deemed to have failed when the defect has not been remedied after the third supplementary performance attempt.
- 9.3 Notification about defects must be made upon delivery without delay. Notification about hidden defects shall take place promptly after their discovery. Such notifications shall state which defects have been detected and whether they were noticed immediately or only after further processing of the parts at issue. LD is entitled to have their own personnel inspect the deficiency.
- 9.4 When a claim for damage compensation is not involved, defect claims become time-barred after 24 months for users and after 12 months for companies, both stated periods beginning with delivery of the goods. Claims for damage compensation as a consequence of redhibitory defects lapse 12 months after delivery of the goods except in cases of personal injury damages, deliberate neglect of duty or gross neglect of duty. The statutory limit for legal claims under a right of recourse remains unaffected.
- 9.5 The buyer does not have the right to withdraw from contract except in the case of neglect of duty for which LD is blameless. The right of termination pursuant to § 649 German Civil Code remains unaffected. If LD is to carry out an adaptation of performance in order to comply with the buyer's order requirements (contract for work), the buyer must provide adequate compensation if he chooses to withdraw from the contract by termination. The amount of compensation shall be commensurate with the necessary overhead already exerted at the point in time the declaration of withdrawal is made, maximum compensation being the agreed contract price. The purchaser is at liberty to prove that less overhead was incurred.
- 10. Liability for usage other than originally intended**
- 10.1 None of the products sold by LD are intended for private consumers (private end users) but rather intended exclusively for use in educational institutions such as general and vocational schools, technical colleges, universities, private or public training centers and industrial operations (intended use).
- 10.2 If the buyer allows third-party private usage of the goods, either occasionally or continuously, regardless of the manner or lawful reason then the buyer has abandoned intended use.
- 10.3 In this case the buyer releases LD from all contractual or legal obligations, claims and duties, including claims under the product liability law, that were associated with original intended use.

GENERAL TERMS AND CONDITIONS OF SALE

11. Liability for property right infringements

- 11.1 Insofar as LD makes no special notification, the delivery item is deemed to be free of third party property rights with respect to awareness of state-of-the-art technology in the Federal Republic of Germany. However, if the delivery item or a part of the same should, at the point in time of contract conclusion, infringe on a property right which has already been issued and published in the Federal Republic of Germany, or if the delivery item explicitly incorporates a particular protected procedural right or infringes on a corresponding procedural right, and consequently results in the instigation of legal proceedings against the buyer then, at its own option and within a reasonable period, LD shall either obtain for the buyer the right of continued utilization, modify the delivery item, part or procedure such that an infringement of third-party rights no longer exists, or withdraw from the contract. LD does not accept any further liability, particularly for procedures, applications and products, etc. Claims against LD for liability due to property right infringements are limited to foreseeable damages.
- 11.2 In the event third-party property rights are infringed upon by drawings or details furnished by the buyer, the buyer shall be responsible for such infringement and indemnify LD against claim.

12. Repairs

- Repairs and returns will be handled by LD exclusively under the following conditions. LD does not recognize any deviating buyer conditions.
- 12.1. Order / cost estimate / repair
- 12.1.1 LD will perform repairs only after receiving a written order.
- 12.1.2 LD will issue an order confirmation for the device received.
- 12.1.3 Cost estimates will only be created at the express request of the ordering party. A cost estimate lump-sum fee of 51.00 Euro will be levied for devices having a replacement value less than 500.00 Euro and 151.00 Euro when replacement value is over 500,00 Euro. When a repair order is issued the cost estimate lump-sum fee will be waived.
- 12.1.4 Repairs made under guarantee will only be performed if a completely filled out return form accompanies the repair return shipment. In this case, the established General Standard Terms and Conditions shall apply.
- 12.1.5 Necessitated by organisational grounds, LD reserves the right to delegate repair work to an LD authorized contract workshop.
- 12.1.6 Repair orders are accepted subject to the procurement of replacement parts.
- 12.2. Shipment
- 12.2.1 If an order is not placed within one month of the date when the cost estimate is issued, the device will be returned without repair.
- 12.2.2 Incurred shipping charges for devices returned without repair, when neither a cost estimate nor a repair order has been issued, shall be borne by the recipient.
- 12.2.3 Return shipment of all devices is carried out at the expense and risk of the customer. On request, LD will insure the device against transport damage and loss at the customer's expense. If transport damage or breakage is determined, application is to be made to the carrier for an assessment of facts. Entitlement to claims for damage will otherwise be lost.
- 12.3. Defect claims and liability
- 12.3.1 Repair service defects apparent within a period of limitation which were already present prior to the transfer of risk will be reworked by LD within a reasonable time at no charge.
- 12.3.2 If the rework fails, the buyer can withdraw from the contract or reduce remuneration.
- 12.3.3 Entitlement to make defect claims expires 12 months after acceptance.
- 12.3.4 After the transfer of risk, there is no entitlement to defect claims for normal wear, for damage ensuing from excessive stresses, for unsuitable equipment or for damage due to exceptional external influences for which the contract has no provisions.
- 12.3.5 If the buyer or third parties make unauthorized modifications or repairs then there shall be no recourse to defect claims arising from these or any consequences thereof.
- 12.3.6 Buyer claims for damage and reimbursement of expenses are excluded, regardless of legal grounds, but in particular with respect to pre-contractual breach of duty, breach of duty arising from indebtedness and tortious liability. This does not apply insofar as liability is mandatory, e.g. in cases of intent and gross neglect, with respect to harm of life, limb or health and for violation of essential contract obligations. However, damage claim compensation for violation of essential contract obligations is limited to contract-typical foreseeable damages insofar as intent or gross negligence is not given. The above provisions do not imply a change in the burden of proof to the detriment of the buyer.
- 12.3.7 No liability is accepted for consumables included with delivery, such as film material, batteries, etc.

13. Other liabilities / liability exclusions

- 13.1 With respect to breaches of contractual and extra-contractual obligations, particularly due to impossibility, delay, and tortious trade, LD – and/or its vicarious agents – shall be liable only in cases of intent and gross negligence, limited to contract-typical damage foreseeable when the contract was concluded.
- 13.2 These limitations do not apply for culpable breach of essential contractual obligations by LD, if fulfilment of the purpose of the contract is endangered, in cases of mandatory liability under the product liability law, by harm to life, limb or health (personal injury), and also not then when LD has deceitfully concealed defects or guaranteed their absence. The rules of burden of proof remain unaffected by this. Essential contract obligations are those LD obligations that enable proper execution of the contract in the first place and on whose observance the buyer can generally expect to have trust.

14. Place of performance, jurisdiction, severability clause

- 14.1 The place of performance shall be Hürth, Germany, unless specified to the contrary in the order confirmation.
- 14.2 The place of jurisdiction is that of the business headquarters for LD Didactic GmbH, currently Hürth, Germany.
- 14.3. Should a provision of these Terms and Conditions or a condition in the context of other agreements be or become invalid, this shall not impair the validity of all remaining provisions or agreements.

15. Applicable law

- The laws of the Federal Republic of Germany shall apply. The application of the standard UN Convention on Contracts for the International Sale of Goods (CISG) is excluded.

Note pursuant to the Federal Data Protection Act LD stores and processes customer data.

LD Didactic GmbH



GENERAL INFORMATION

Customer desk	+ (49) 22 33 / 604 - 430	
	Order processing	
	Available Mon.-Thur. from 8.00 am- 4.00 pm and Fr. from 8.00 am - 2.45 pm	
Order fax	+ (49) 22 33 / 604 - 193	
Help-Line	+ (49) 22 33 / 604 - 301	
	Technical support for queries, advice on equipment or experiments	
	Available Tues. from 10.00 am - 12.00 pm and Thur. from 2.00 pm - 4.00 pm	
E-mail	info@ld-didactic.de	
Internet	WWW.LD-DIDACTIC.COM	WWW.LEYBOLD-SHOP.COM

INFORMATION CONCERNING TENDERS

Your contact partners Mr. Kattwinkel and Mr. Schilling are at your disposal from Mon.-Thur. from 8.00 am to 4.00 pm and Fr. 8.00 am to 2.45 pm.

Contact data:

Achim Kattwinkel

Telefon + (49) 22 33 / 604 - 272

E-mail akattwinkel@ld-didactic.de

Hans Peter Schilling

Telefon + (49) 22 33 / 604 - 305

E-mail pschilling@ld-didactic.de

TECHNICAL SERVICE

Should you have any questions regarding a component or an equipment set: Our service team is at your disposal by phone at + (49) 22 33 604 - 430 and per E-mail under service@ld-didactic.de.

YOUR PERSONAL TECHNICAL ADVISOR

You can find the contact data of the technical advisor you need on our internet page.

PHYSICS

CHEMISTRY
BIOLOGY

ENGINEERING



1308012_06.2014 LD
Technical details subject to change without notice

CONTACT

GERMANY:

LD DIDACTIC GmbH
Leyboldstr. 1
D-50354 Huerth
Germany
Tel.: +49 2233 604 0
Fax: +49 2233 604 222
Email: info@ld-didactic.de
www.ld-didactic.com

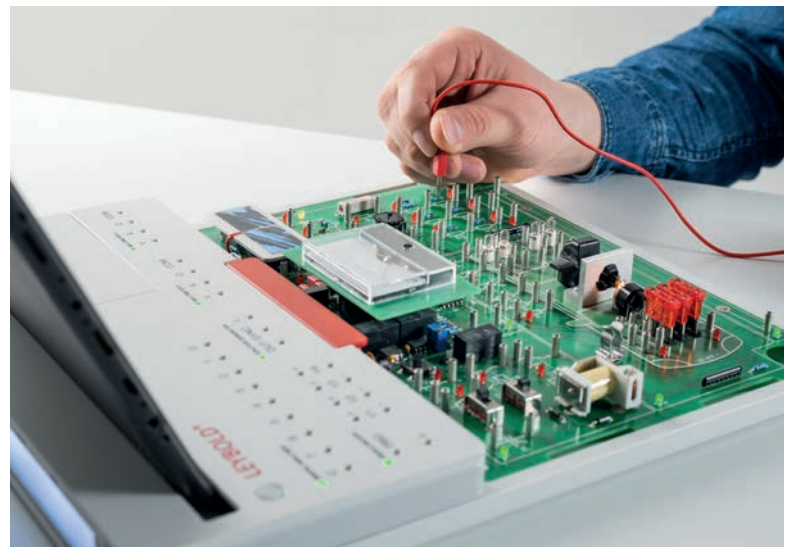

WWW.LD-DIDACTIC.COM

BRANDS OF THE LD DIDACTIC GROUP

LEYBOLD® **Feedback** **ELWE**® **TECHNIK**